

# Installation/Owners Manual



## **Sentry<sup>®</sup>** **Swing Gate Operator** 16 Inch Stroke



*Designed to open all types of gates  
in all kinds of places.*

**MADE IN THE USA**

**3 Year Warranty**

**Heavy Duty**

**Battery Powered**

**Solar or AC Charged**

# ATTENTION

## The supplied Photo Eye must be installed for Gate Operation

Effective August 1, 2018 a vehicular swing gate operator must have provisions for, or be supplied with, at least two independent entrapment protection means for each direction of travel as specified in current UL325 standard Table 31.1. At installation, both entrapment protection devices must be installed and operational before gate operation is allowed. \*Exception allowed if no entrapment exist in one direction of travel then only 1 device is required, the other direction must have 2 entrapment protection devices active. The gate operator will monitor for proper operation before movement is allowed.

USA automatic control boards utilize type A (Inherent entrapment protection system) as the first entrapment protection means identified. The second entrapment device identified must be a monitored Type B1 or Type B2 device that has been tested and approved with the gate operator. These devices are listed below.

USA automatic control boards can monitor one photo eye (B1) for the open direction, one photo eye (B1) for the closed direction and one contact edge (B2) for the open/close direction. If additional entrapment devices are required the USA automatic expansion module (part # 500015) is required

Type B1 - Non-contact sensor (photoelectric sensor or the equivalent). Identified as Normally Closed N/C contact switching.

Type B2 - Contact sensor (edge device or the equivalent). Identified as 10K resistor installed for presence monitoring.

Type D - Actuating device requiring continuous pressure to maintain motion of the gate.  
User must be within sight of the gate and verify gate path is clear before operating.

### External entrapment devices approved for use are listed below

#### Wired Contact Edge Type B2 Devices

**Manufacturer: ASO**

Models: Sentir Edge 95.25, 92.20, 85, 35.55, 65, 25.30, 25.45, 15.10

**Manufacturer: Miller Edge**

Models: MGR20, MGS20, ME120, MG020, ME112, MG123

#### Non-Contact sensors (photoelectric sensor or the equivalent) Type B1 Devices

**Manufacturer: USA automatic, LLC**

Models: 550011, 550014

It is the responsibility of the installer to identify all entrapment areas and install the appropriate compliant monitored entrapment device or devices to protect each area identified.



# ENTRAPMENT ZONES

The illustrations below are a guide to help identify entrapment areas for swing gate installations that must be protected. Other entrapment areas may exist and must be identified by the installer and protected by the appropriate entrapment protection device for the situation.

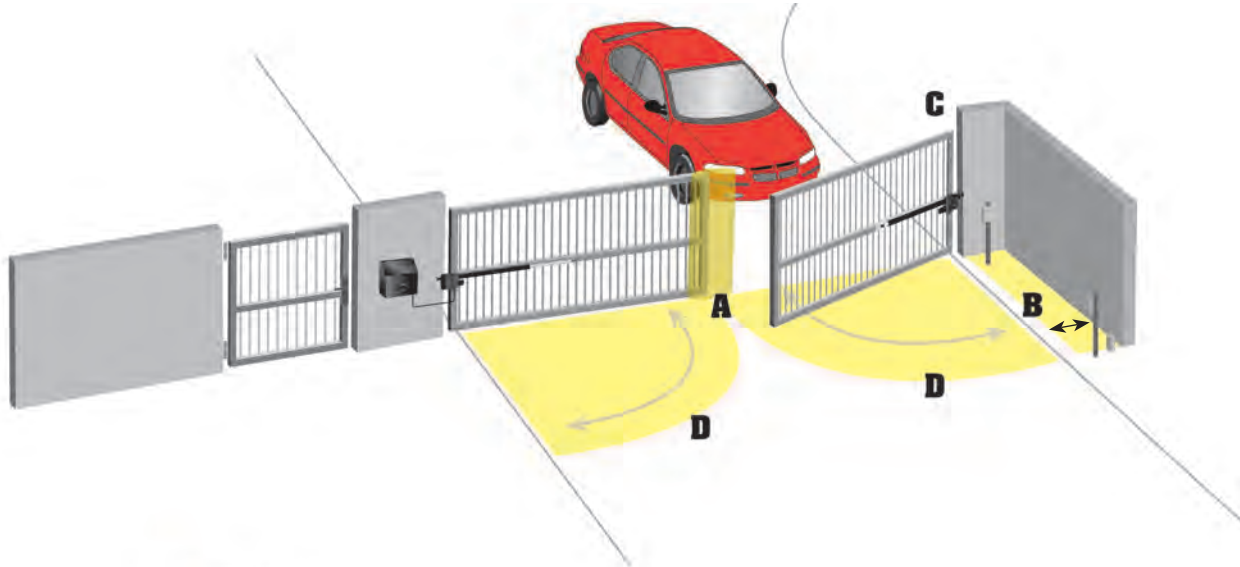

**Zone A** - Leading edge of gate where it meets a 2nd gate, stop post or passes a column or post corner. - recommended monitored entrapment protection type is B2 contact sensor or equivalent.

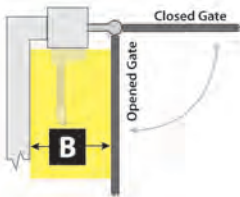

**Zone B** - Gate opens toward an immovable object with less than 16 inches (40.6 cm) of clearance - recommended monitored entrapment protection type B1 photo eye or equivalent. If space is less than 16" (40.6 cm), entrapment protection in this area is required.

*(ASTM F2200: 7.1.1.1 and 7.1.1.2)*

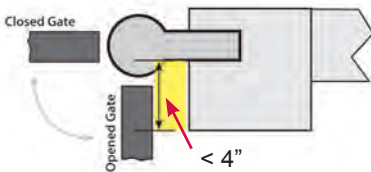

**Zone C** - If distance from center of hinge rotation point to corner of column, post or immovable object is greater than 4 inches (10.16 cm), recommended monitored entrapment protection type is B2 contact sensor or equivalent.

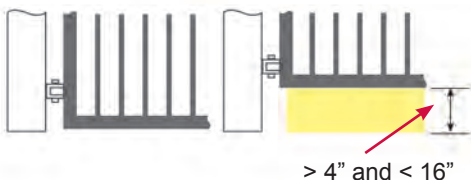

**Zone D** - If the bottom edge of a swing gate is greater than 4 inches (10.16 cm) and less than 16 inches (40.6 cm) above the ground at any point in its arc of travel, one or more contact sensors must be located on the bottom edge of the gate.



# Sentry Series AUTOMATIC GATE OPERATORS

**This Sentry Gate Operator is intended to be installed on the four different classes of gate operators identified in the UL325 Standards.**

## RESIDENTIAL VEHICULAR GATE OPERATOR – CLASS I

A vehicular gate operator (or system) intended for use in garages or parking areas associated with a residence of one-to four single families.

## COMMERCIAL/GENERAL ACCESS VEHICULAR GATE OPERATOR – CLASS II

A vehicular gate operator (or system) intended for use in a commercial location or building such as a multi-family housing unit (five or more single family units), hotel, garages, retail store, or other buildings accessible by or servicing the general public.

## INDUSTRIAL/LIMITED ACCESS VEHICULAR GATE OPERATOR – CLASS III

A vehicular gate operator (or system) intended for use in an industrial location or building such as a factory or loading dock area or other locations not accessible by or intended to service the general public.

## RESTRICTED ACCESS VEHICULAR GATE OPERATOR – CLASS IV

A vehicular gate operator (or system) intended for use in a guarded industrial location or building such as an airport security area or other restricted access locations not servicing the general public, in which unauthorized access is prevented via supervision by security personnel.

## Solar Friendly

The system design and the accessories recommended are all Solar Friendly meaning that they require the least amount of energy possible to perform the job they were designed to do. The solar option allows you to install the gate operator in remote areas or in applications where you prefer to be solar charged. Solar charging provides additional isolation from lightning that might damage the unit via the AC power needed for the DC adapter .

## BATTERY REQUIRED FOR OPERATION *(Battery not included)*

### Recommended battery type:

Battery 12-volt, Group U-1; sealed (maintenance free); 30 amp hour minimum.

Using a smaller amp hour battery may cause damage to the charging system.

The wiring harness has two 1/4" ring terminals to connect to battery posts.

**CAUTION: Do not install wet cell battery into control box; this type of battery usually has removable caps used for service and will vent into control box.**

The battery is charged using the 120V DC Adaptor (PN #520009) **OR** the Solar Panel kit (PN 520026). For information on what you can expect from a solar charged system see the solar charging section of this manual.

## **PLEASE READ THE ENTIRE MANUAL CAREFULLY PRIOR TO INSTALLATION.**

Study the entire Safety Section paying particularly close attention to the entrapment zones and install monitored entrapment devices to protect all entrapment zones identified. Installation by a Qualified Technician is recommended to verify all safety concerns are addressed.

**Warranty is VOID if warranty registration is not completed within 30 days of purchase**

© USAutomatic, LLC, 2021 rev. A

All rights reserved. No part of this manual may be reproduced by any means without the expressed written consent of the publisher.

USAutomatic Part # 720101



# TABLE OF CONTENTS

## INTRODUCTION

- Entrapment Devices Required and Approved for Operation .....i
- Entrapment Zones .....ii
- Important Safety Instructions ..... 3-4
- Sentry Parts Inventory ..... 5-6
- General Tool Requirements / Actuator Dimensions .....7
- Control Box Dimensions / Gate Qualifications/Applications.....8
- Proper Gate Design .....9

## INSTALLATION STEPS

- 1. Mounting Site Review .....10
- 2. Determine Proper Brackets and Opening Method ..... 11
- 3. Pull to Open Installation ..... 12
- 4. Push to Open Installation ..... 13
- 5. Determine Horizontal Mounting Location ..... 14
- 6. Attach Universal Actuator Bracket to hinge post or post being used ..... 15
- 7. Attach Actuator Bracket to Universal Actuator Bracket ..... 16
- 8. Install Linear Actuator to Actuator Bracket ..... 16
- 9. Install Gate Bracket to Linear Actuator ..... 17
- 10. Install Gate Bracket to Gate ..... 17
- 11. Preparing Sentry Control Box for Installation ..... 17
- 12. Install Sentry Control Box ..... 18
- 13. Splicing Linear Actuator Cable or Installing 2nd Linear Actuator Cable for Dual Gate System ..... 19
- 14. Installing Monitored Entrapment Protection Devices ..... 20
  - Monitored Photo Eye (Type B1) Installation ..... 20
  - Monitored Contact Edge (Type B2) Installation ..... 20
  - Constant Pressure (Type D) Installation ..... 20
- 15. Install Battery ..... 22
- 16. Install Power Source - DC Adaptor or Solar Panel ..... 22
- 17. Solar Charged System ..... 22-23
- 18. Connect Power Source to Battery Controller ..... 24
- 19. Sentry Plug N Go Harness Final Installation ..... 24
- 20. Gate Delay ..... 25
- 21. Photo Eye Alignment ..... 25
- 22. Install Safety Signs ..... 25
- 23. Operating Gate For The First Time ..... 26
- 24. Limit Adjustments ..... 27
- 25. Sensitivity Adjustments and Entrapment Alarm and Auto Close Setting ..... 28
- 26. Verifying Monitored Entrapment Protection System (Type A) Operation ..... 28
- 26. Verifying Monitored Photo Eye (Type B1) ..... 29
- 26. Verifying Monitored Contact Edge (Type B2) ..... 29
- 26. Verifying Constant Pressure (Type D) ..... 29
- 27. Sentry Control Board Information ..... 30-32
- 28. Programming Transmitter, Receiver and Wireless Keypad ..... 33-36
- 29. Emergency Manual Release ..... 37

## PERIODIC SERVICE ..... 37

## ACCESSORIES ..... 38-41

## TROUBLESHOOTING GUIDE ..... 42

## APPENDIX

- A. Photo Eye Vehicular Protection Only ..... 43-44
- B. USAutomatic Battery Controller ..... 45
- C. Installing APP Receiver ..... 46

## WARRANTY ..... 47-48



# IMPORTANT SAFETY INSTRUCTIONS

## WARNING - TO REDUCE THE RISK OF INJURY OR DEATH

1. READ AND FOLLOW ALL INSTRUCTIONS
2. SAVE THESE INSTRUCTIONS!!
3. Always keep people and objects away from the gate. NO ONE SHOULD CROSS THE PATH OF A MOVING GATE.
4. Test gate operator monthly. The gate must stop and reverse directions upon contacting a rigid object or when the secondary entrapment device is activated.
5. After all adjustments have been made to the sensitivity (current sense) circuit, secondary entrapment devices and all other external devices installed, the safety devices must be checked again. Failure to adjust and retest the gate operator can increase the risk of injury or death. A Qualified technician should check these periodically for proper operation.
6. Use the emergency release ONLY when gate is not moving.
7. KEEP GATES PROPERLY MAINTAINED. Tighten all bolts and grease hinges and pivot points.
8. THE ENTRANCE IS TO BE USED BY VEHICLES ONLY. Pedestrians must use a separate entrance.
9. Never let children operate or play with gate controls or any other activation device. Keep remote control away from children.
10. The operator is intended for installation only on gates used for vehicles. Pedestrians must be supplied with a separate access opening. The pedestrian access opening shall be designed to promote pedestrian usage. Locate the gate such that persons will not come in contact with the vehicular gate during the entire path of travel.
11. The gate must be installed in a location so that enough clearance is supplied between the gate and adjacent structures when opening and closing to reduce the risk of entrapment.
12. Do not attempt to enter the gate area while the gate is moving. Wait until the gate comes to a complete stop.
13. DO NOT ALLOW CHILDREN TO PLAY IN THE AREA OF THE GATE.
14. Do not allow anyone to ride on the gate.
15. Operate the gate only when it is fully visible, free of persons or obstructions, and properly adjusted.
16. All controls are located at least six feet away from the gate to eliminate the chance of the person operating the gate from coming in contact with the moving gate. Do not install external buttons, which can be used to operate the gate within the reach of children.  
*\*Exception: Emergency access controls only accessible by authorized personnel may be placed at any location in line-of-sight of the gate.*
17. Both Safety Signs are installed, one on each side of the gate and visible in the gate area.

# SAFETY INSTALLATION INFORMATION

## Install the gate operator when:

- Operator is appropriate for the construction of the gate and usage class is correct for the installation.
- All exposed pinch points are eliminated or guarded.
- The gate is installed in a location where enough space is supplied between adjacent structures and the gate that when opening or closing the chance of entrapment is reduced.
- The gate is properly installed and moves freely in both directions. Do not over adjust the sensitivity adjustment to compensate for an improper gate installation.
- All hard wired sensors used for monitored entrapment protection devices and their wiring are installed in a manner which protects them from mechanical damage.
- The Reset button must be located in the line-of-sight of the gate. Activation of the reset button shall not cause the operator to start.

## Non Contact Sensors - Type B1 - Photo Eyes or equivalent

1. See entrapment zones for suggestions on placement of sensors.
2. Care shall be exercised to reduce the risk of nuisance tripping, such as when a vehicle trips the sensor while the gate is still moving.
3. One or more non-contact sensors shall be located where the risk of entrapment or obstruction exist, such as the area reachable by a moving gate.

## Contact Sensors - Type B2 - Contact Edge or equivalent

1. See entrapment zones for suggestions on placement of sensors.
2. One or more sensors shall be located on the inside and outside leading edge of a swing gate.
3. Additionally, if the bottom edge of a swing gate is greater than 4 inches (101.6mm) and less than 16 inches (406mm) above ground at any point in its arc of travel one or more sensors shall be located on the bottom edge.
4. A hard wired sensor shall be located and its wiring arranged so that the wiring between the sensor and the gate operator is not subjected to mechanical damage.
5. A wireless device such as one that transmits (RF) signals to the gate operator for entrapment protection functions shall be located where the transmission of the signals are not obstructed or impeded by building structures , natural landscaping or similar obstruction. A wireless device shall function under the intended end-use conditions.

## Constant Pressure - Type D - Emergency switch or equivalent

1. The gate operator controls must be placed so that the user has full view of the gate area when the gate is moving.
2. An automatic closing device (such as a timer, loop sensor, or similar device) shall not be employed and no other activation device shall be connected.
3. Placard required shall be placed adjacent to the controls.



# PARTS INVENTORY

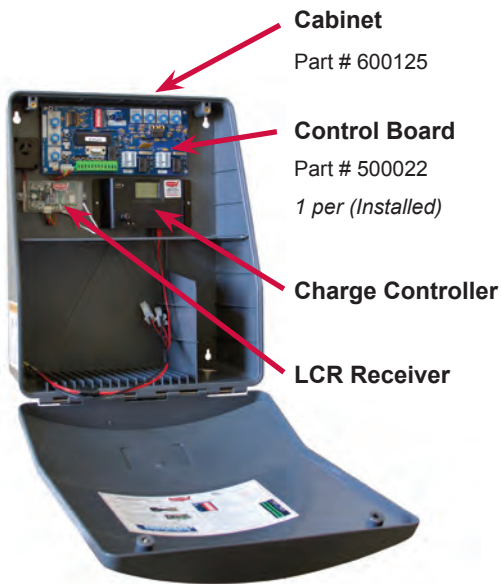

**Cabinet**  
Part # 600125

**Control Board**  
Part # 500022  
1 per (Installed)

**Charge Controller**

**LCR Receiver**

**Linear Actuator**  
Part # 510310  
1 per



**Universal Actuator Bracket**

Part # 610400  
1 per



**Square Post Flush Mount Bracket**

Part # 610402  
1 per



**Round Post Flush Mount Bracket**

Part # 610404  
1 per



**Actuator Bracket**

Part # 610406  
1 per



**Gate Bracket**

Part # 610105  
1 per



**Gate Support Bracket**

Part # 610120  
2 per



**Bronze Bushing**

Part # 610530  
2 per



**Manual release pin**

Part # 610534  
1 per



**Manual release clip**

Part # 610535  
1 per



**Plug N Go Harness**

Part # 630040  
1 per



**1/2" Cable Gland**

Part # 620022  
1 per



**Entrapment Siren**

Part # 530015  
1 per (Installed)



**Safety Sign**

Part # 601027  
2 per



**Photo Eyes**

Part # 550011  
1 set per



**Transmitter**

Part # 030210  
2 per



**DC Adapter (20 vdc and 1.2 Amps)**

Part # 520009  
1 per



**Charge Controller**

Part # 520001  
1 per (Installed)

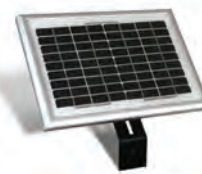

**Solar Panel Kit**

10 Watt  
Part #520026  
1 per



**LCR Receiver**

Part # 030200  
1 per (Installed)



# HARDWARE INVENTORY



**3/8 x 16 nylon lock nut**  
Part # 610518  
5 per



**1/4 x 20 nylon lock nut**  
Part # 610526  
2 per



**3/8 USS flat washer**  
Part # 610514  
6 per



**3/8 SAE flat washer**  
Part # 610516  
2 per



**1/4 SAE flat washer**  
Part # 610524  
4 per



**Nylon washer**  
Part # 610528  
2 per



**3/8 x 2 1/2" shoulder bolt**  
Part # 610512  
3 per



**3/8 x 16 x 8" carriage bolt**  
Part # 610510  
2 per



**Tap bolt**  
**1/4 x 20 x 3 1/2"**  
Part # 610522  
2 per



**Tap bolt**  
**1/4 x 20 x 2 1/2"**  
Part # 610520  
2 per



**#12 x 1 1/4 self tap hex screw**  
Part # 610532  
4 per

## SENTRY DUAL GATE HARDWARE ALSO INCLUDES:

**Linear Actuator**  
Part # 510310 1 per

**Universal Actuator Bracket**  
Part # 610400 1 per

**Square Post Flush Mount Bracket**  
Part # 610402 1 per

**Round Post Flush Mount Bracket**  
Part # 610404 1 per

**Actuator Bracket**  
Part # 610406 1 per

**Gate Bracket**  
Part # 610105 1 per

**Gate Support Bracket**  
Part # 610120 2 per

**Bronze Bushing**  
Part # 610530 2 per

**Manual release pin**  
Part # 610534 1 per

**Manual release clip**  
Part # 610535 1 per

**50 Ft 7 Conductor Extension Cable**  
Part # 630035 1 per

**Junction Box**  
Part # 630045 1 per

**Wire Nut**  
Part # 620320 4 per

**Wire Nut**  
Part # 620310 6 per

**3/8 x 2.5" Shoulder Bolt**  
Part # 610512 3 per

**3/8 x 8" Carriage Bolt**  
Part # 610510 2 per

**1/4 x 20 x 3 1/2" Tap Bolt**  
Part # 610522 2 per

**1/4 x 20 x 2 1/2" Tap Bolt**  
Part # 610520 2 per

**#8 x 3/4 Self tap hex screw**  
Part # 610615 2 per

**3/8 x 16 nylon lock nut**  
Part # 610518 5 per

**1/4 x 20 nylon lock nut**  
Part # 610526 2 per

**3/8 USS flat washer**  
Part # 610514 6 per

**3/8 SAE flat washer**  
Part # 610516 2 per

**1/4 SAE flat washer**  
Part # 610524 4 per

**Nylon washer**  
Part # 610528 2 per



## GENERAL TOOL REQUIREMENTS

- SAE Standard wrenches & sockets
- Nut driver
- Level and tape measure
- Pliers
- Wire Cutters/Strippers
- Welder
- Drill and bits
- Drill adapter for socket attachment
- Hack saw

Welding is the recommended method of securing the linear actuator mounts to the gate and hinge post. Bolt on brackets require frequent service to keep tight. They must be very securely attached (i.e. carriage bolts with lock nuts and washers). Lag type bolts are not recommended. Loose or unstable linear actuator mounts will result in improper operation.

## ACTUATOR DIMENSIONS

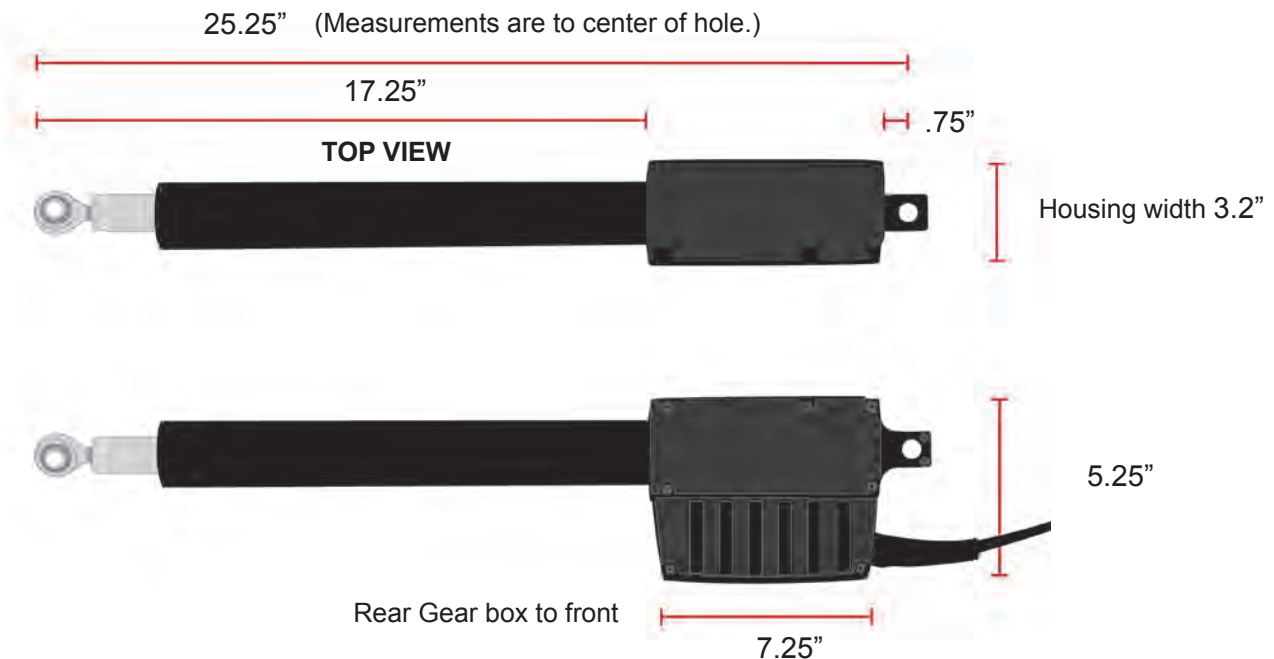

## BOX DIMENSIONS

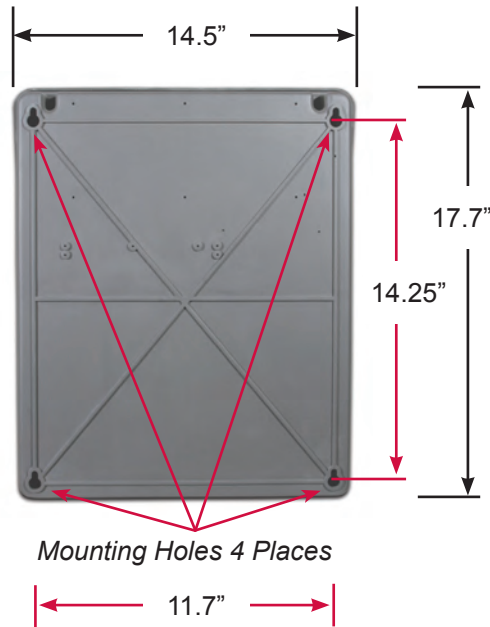

## GATE QUALIFICATIONS/APPLICATIONS

The pictures below are provided as a guide to help understand the types of gates and size to provide many years of operation.



### Ornamental Iron

13 feet max length. Max weight 400 lbs.



### Farm Gate

20 feet max length. Max weight 250 lbs.



### Ranch Gate

16 feet length. Max weight 300 lbs.



### Chain Link Gate

14 feet length. Max weight 350 lbs.

## PROPER GATE DESIGN

### IMPORTANT- A GATE OPERATOR CANNOT OVERCOME A POORLY DESIGNED GATE.

Since the gate is a major component of the system, great care and concern must be given to the gate design. USAutomatic, LLC is not responsible for any damage to a gate on which the gate operator is installed. A poorly installed or misadjusted gate could be damaged. It is the responsibility of the installer to verify proper gate installation prior to operator installation. As a general rule, a gate, which is to be automatically operated, must be stronger and smoother than one operated manually.

- Does the gate swing smoothly without binds or excessive resistance?
- Swing gates should swing level and plumb to prevent the operator from having to lift the gate open or closed.
- Swing gates should not require a wheel to support them. Wheels create drag, which will cause operator problems. A wheel is generally a sign of a weak hinge system or a weak gate frame.
- Is the gate frame of substantial strength without excessive weight?
- Will the frame withstand normal wind load conditions without sway or vibration?
- Will the gate close correctly without being hand-guided or lifted to close?
- Are the hinges suited for an automatic gate operator? We recommend bearing type hinges to reduce friction drag.
- Will a reinforcement brace be required to attach the linear actuator to the gate or does a suitable cross member exist in the gate design?

**If any of these problems exist, they must be corrected to achieve a reliable automatic gate system.**

All Gates must have smooth bottom edges, no protrusions should exist. If gate hardware or sensors protrude, they must have smooth surfaces free of any sharp cutting edges that do not exceed  $\frac{1}{2}$  inch beyond the base of the gate. (ASTM F2200: 4.8)

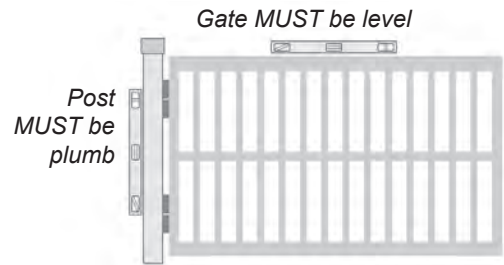

Gate should not require a wheel for support.



Gate should not be unlevel due to weak frame.



Gate should not be unlevel due to unlevel post.

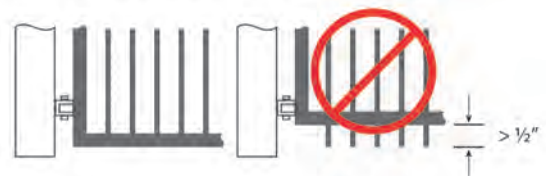



## Mounting Site Review

Review the following items prior to installation and predetermine the solution to any problems which may exist:

1. Does sufficient space exist for mounting and future servicing of the operator and control box?
2. Which direction will the gate swing?
  - a. Will the gate operator pull the gate open to the inside (Pull to Open)?
  - b. Will the gate operator push the gate open to the outside (Push to Open)?  
(See Determine Opening Method Section)
3. Where and how will the actuator mounting brackets be secured to the hinge post and to the gate? (See Determine Actuator Mounting Brackets Sections)
4. How will the gate bracket be secured to the gate and will additional reinforcement be required? (See Mount Support Bracket Section)
5. Where will the control box be mounted to support the weight of the battery and other components and can it be located within 8 feet to prevent splicing of the linear actuator cable? (See Install Sentry Control Box Section)
6. For AC Charged System - How far away is the 120 VAC receptacle for the transformer? Transformer is supplied with 10 feet of cable. If extension is needed use power source cable Extension Kit part #630038. See Power Source Cable Extension chart for identifying the wire size needed for the distance required. Transformer must be installed indoors or in a rain tight enclosure. Transformer should not be exposed to moisture.
7. For Solar Charged System - Where will the solar panel mount so that optimum sunlight is received? Solar panel is provided with 15 feet of cable, If extension is needed use power source cable Extension Kit part #630038 or 75' Solar Extension part #520016. See Power Source Cable Extension chart for identifying the wire size needed for the distance required. Solar panel typically needs to be facing a South or Southwest direction.
8. How will accessory control wiring, if any, be brought to the control box? Knock outs are provided in control box bottom for conduit.
9. Have all safety concerns been addressed? Study the Safety Section and Entrapment Zones for more information.
10. Identify entrapment areas. Determine the appropriate UL325 compliant monitored entrapment device/devices that will be used to protect all entrapment areas.
11. Is there enough space beneath the linear actuator for the cable so that damage to the cable does not occur? Actuator must not be installed with cable on the top side of the actuator. Cable must exit actuator on the bottom side to prevent water from entering housing. (See Horizontal Mounting Location Section)



## 2

## Determine Proper Brackets and Opening Method

### Mounting Brackets

#### Determining which of the brackets will be needed for your installation.

The Sentry gate opener is supplied with universal brackets to mount on round or square hinge post. Some pieces may not be needed for your installation.

The hinge post is the post your gate hinges are attached to. Follow the steps below to identify which of the included brackets will be needed for your installation.

#### Is the hinge post round or square?

Square post will use the “square post flush mount bracket”

Round post will use the “round post flush mount bracket”

**NOTE:** If a round post is to be used it might be necessary to brace the post so that it does not rotate. A round post simply installed in concrete will rotate, if possible drill holes through the post and insert rebar through the post prior to concrete to prevent rotation.

#### Is the gate a light weight farm gate?

If so, use the “gate support brackets” to attach the gate bracket so that the bolts can be securely tightened.

### Universal Actuator Bracket

The universal actuator bracket can be installed in many different ways to accommodate your gate opener installation. Use the images below to help understand the mounting options for this bracket and determine the installation method you are going to use. The images are for reference only and your installation might differ.

Universal actuator bracket must be securely installed. Drilling through the post is the strongest method. It is also recommended that the square post flush mount bracket or the round post flush mount bracket be installed for strength on opposite side of post from the universal bracket (see figures below).

When determining where the universal actuator bracket will mount on the hinge post you must also consider where the gate bracket is going to connect to the gate. The gate bracket is going to attach approximately 34” out on the gate measured from the gate hinge center. Once universal actuator bracket location is determined, verify that the gate bracket can be installed to the gate so that linear actuator is level.

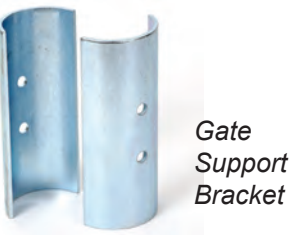
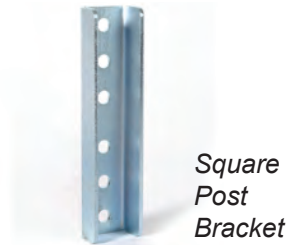

### 3 Pull to Open Installation

This installation method is the most common where the gate swings into the property/driveway.

No matter which way you decide to install the actuator bracket and universal actuator bracket the pivot point below must be located in approximately this position for a pull to open installation.

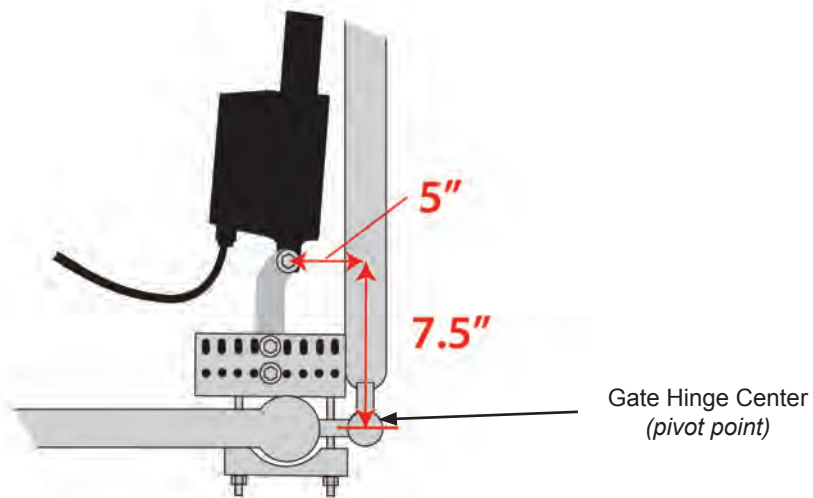
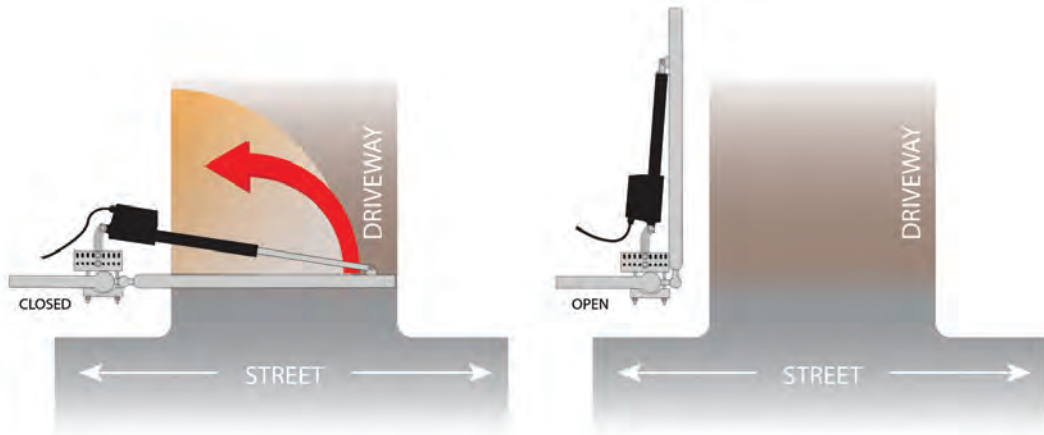

PULL TO OPEN - Actuator Hinge Mounting Tube Installation Dimensions		
Gate opening in degrees	Sentry Pro80 Dimension A	Sentry Pro80 Dimension B
90 degree opening	5"	7½"
100 degree opening	7"	7"
105 degree opening	8"	5½"

## 4 Push to Open Installation

This installation method is common where the driveway slopes up entering the property and gate must swing out to avoid interference. This type of installation places the actuator bracket and linear actuator into the drive area slightly. Another installation method would be to install as a Pull to Open and place linear actuator on outside of property.

Push to open installation can be achieved by installing universal actuator bracket and actuator bracket as shown in figure below. Dimensions for this install method are 7" and 4" from hinge center. Universal actuator bracket hole pattern allows for the actuator bracket to be installed as shown in this location only. Establish enough offset in the rear actuator pivot point to allow the gate to close from the open position.

**IMPORTANT: If Installation is Push to Open, control switch #9 "operating direction reverse" must be turned "ON".**

**NOTE: Pull to Open & Push to Open Dimensions are measured from the gate hinge center (pivot point).**

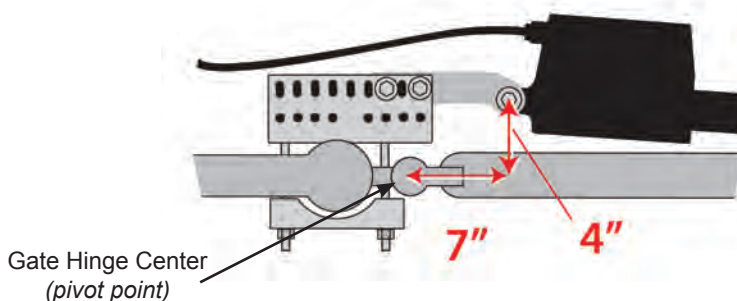
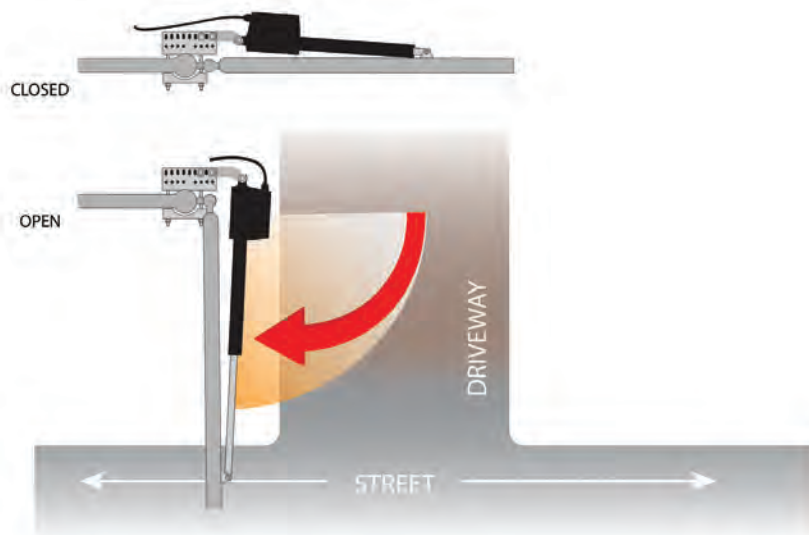

PUSH TO OPEN - Actuator Hinge Mounting Tube Installation Dimensions		
Gate opening in degrees	Sentry Pro80 Dimension A	Sentry Pro80 Dimension B
90 degree opening	7"	4"
100 degree opening	8.5"	4"



## 5 Determine Horizontal Mounting Location

Now that the type of installation (pull to open or push to open) has been determined, the vertical height position of the support bracket and actuator mounting tube must be determined. Refer to these examples to determine the mounting location of the gate bracket on the gate, which is needed to determine the location of the universal actuator bracket.

The actuator delivers force on the gate when operating. Aligning the actuator mounts with a horizontal gate frame member is the best choice. (as shown here)

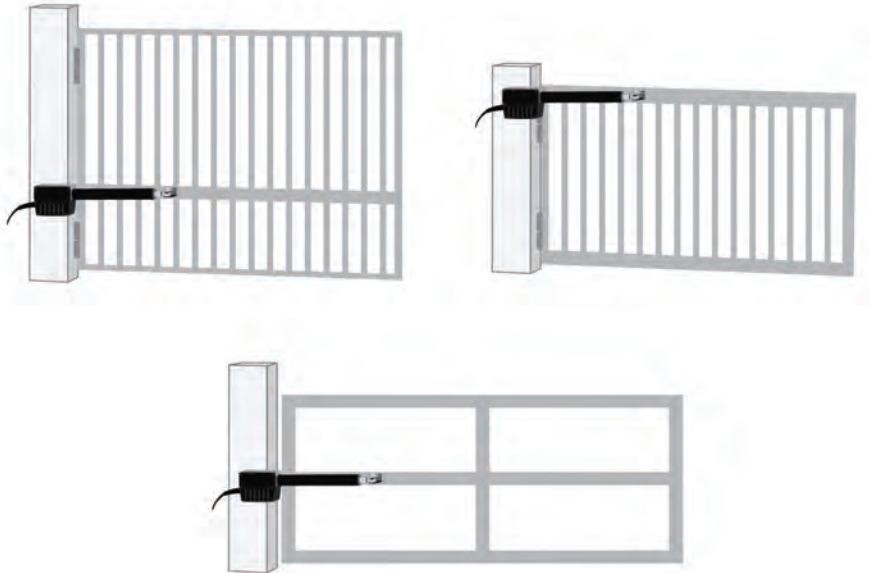

Installation of a horizontal brace may be necessary to prevent damage to vertical gate pickets.

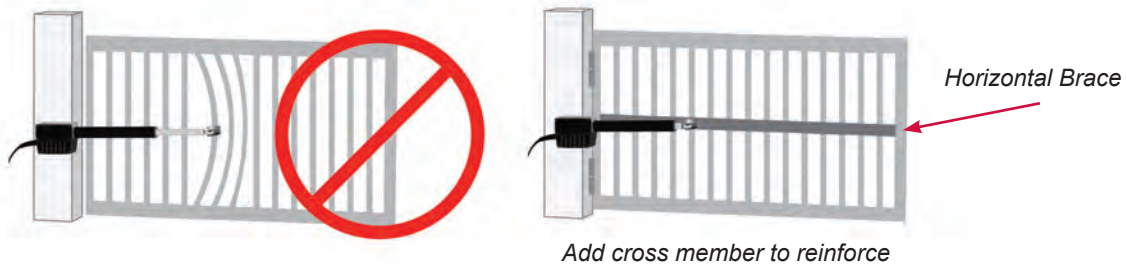

Avoid mounting actuator on bottom rail of gate where actuator might be exposed to flooding and cable exposed to damage from animals and lawn equipment.

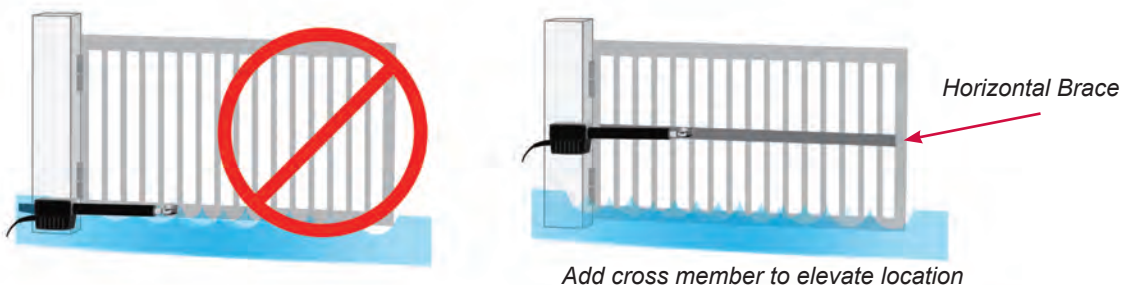

## 6

### Attach Universal Actuator Bracket to hinge post or post being used

#### Mounting hardware needed:

- two 3/8" x 16 x 8" carriage bolts
- two 3/8" USS flat washers
- two 3/8" nylon lock nuts

The universal actuator bracket can be installed in many different ways to accommodate your gate opener installation. The pictures here are for reference and your installation might differ.



Universal actuator bracket must be securely installed. Drilling through the post is the strongest method.

**NOTE: In all cases, the universal actuator bracket should be aligned level with a horizontal gate section.**

1. Attach Universal Actuator Bracket with associated bracket (round or square post mount) as previously determined to work best with your opening method. It is recommended that the square post flush mount bracket or the round post flush mount bracket be installed for strength on opposite side of post from the universal bracket.
2. Install with carriage bolts, lock nuts and washers.
3. Tighten nuts securely.



Welding is the recommended method of securing the linear actuator mounts to the gate and hinge post. Bolt on brackets are provided and are acceptable but may require frequent service to keep tight. They must be very securely attached (i.e. carriage bolts with lock nuts and washers). Lag type bolts are not recommended. Loose or unstable linear actuator mounts will result in improper operation.

#### **IMPORTANT CAUTIONS:**

1. Do not perform any welding with the actuator cable plugged into the control board or the battery connected. Serious damage to the control board and/or battery may occur if attempted.
2. Always disconnect the battery power from the control board using the Plug N Go harness prior to wiring any devices to the control board.

## 7 Attach Actuator Bracket to Universal Actuator Bracket

The actuator bracket has a 3/8" pre drilled hole that the linear actuator will mount to. This is the pivot point for the linear actuator. In all cases, the universal actuator bracket should be aligned level with a horizontal gate section. (see Mounting Site Review)

**For a Pull to Open installation** - the pre-drilled hole must be located 5" behind the gate hinge and 8" to the inside of the property.

**For a Push to Open installation** - the pre-drilled hole must be located 7" in front of the gate hinge and 4" to the drive side of the hinge.

These dimensions are measured from the center of the gate hinge (pivot point).

### Hardware needed:

- two 3/8" x 2 1/2" shoulder bolts
- two 3/8" USS flat washers
- two 3/8" nylon lock nuts.

1. Attach actuator bracket to universal actuator bracket.
2. Verify that actuator bracket pivot hole dimension is located in the correct position.
3. Tighten bolts securely.

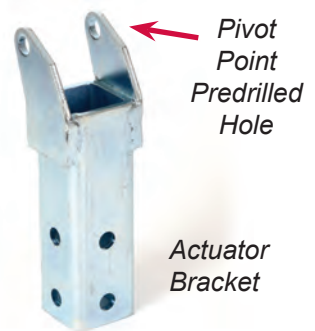

## 8 Install Linear Actuator to Actuator Bracket

The actuator can be mounted in two different positions as shown. Installing the actuator on its side can allow for hiding it behind a cross member in the gate frame.

### Bronze Bushing

Part # 610530

### Nylon Washer

Part # 610528

### Nylon Washer

Part # 610528

### Bronze Bushing

Part # 610530

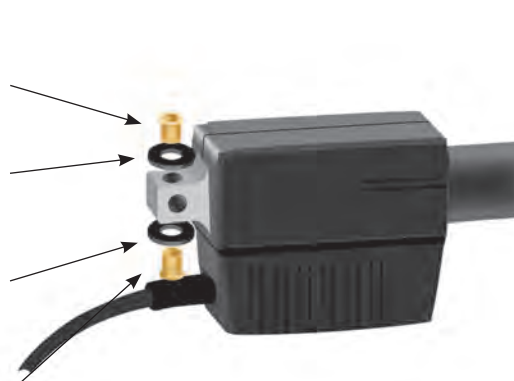

### 3/8" Bolt Part # 610512

### 3/8" SAE Flat Washer Part #610516

### Actuator Bracket Part # 610406

### 3/8" SAE Flat Washer Part #610516

### 3/8 inch Lock Nut Part # 610518

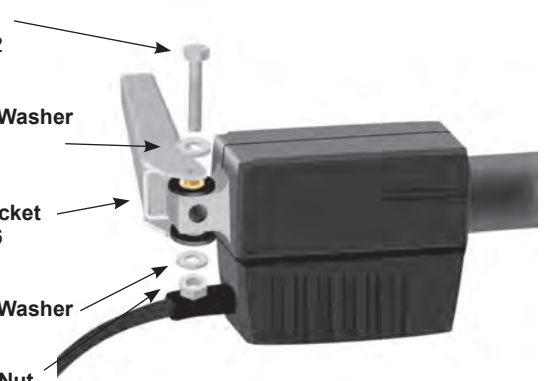

**CAUTION:** If mounting actuator on its side, ensure actuator case does not come in contact with any objects. Mount as shown so that wide part of motor case and cable is away from gate.

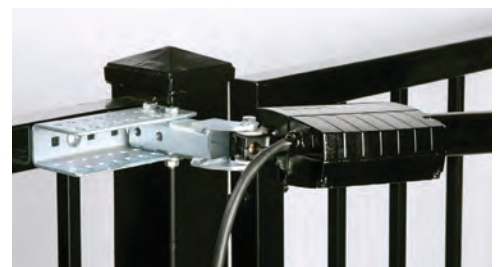

## 9 Install Gate Bracket to Linear Actuator

Install manual release pin, gate bracket and manual release clip to linear actuator extension rod end.

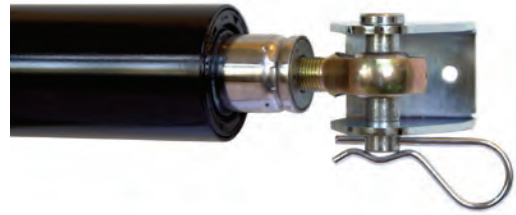

## 10 Install Gate Bracket to Gate (Pull to Open Only)

To determine where the gate bracket will be installed follow these steps: The linear actuator should be connected to the actuator bracket at this point. **NOTE - The linear actuator was shipped from the factory set to the fully retracted position.**

1. Swing gate to the fully open position.
2. Now open gate another couple of inches (the gate will never open more than this position). The gate can be adjusted later to open a little less if needed.
3. Swing linear actuator around (should swing freely) in a level position to meet the fully open gate. This is where you should install the gate bracket on the gate.
4. Mark the location of the 1/4" holes for the mounting bracket. (see figure)
5. Remove pin and clip from bracket.
6. Attach bracket to gate (if using a light weight tubular farm gate use gate support bracket for support). Use the 1/4" x 2 1/2" or 3 1/4" tap bolts depending on gate thickness, four 1/4" flat washers and two 1/4" nylon lock nuts. Tighten securely.
7. Attach actuator to the now secured gate bracket using manual release pin and clip.
8. The gate should now be fully opened with the actuator attached.
9. Verify that linear actuator is level and all pieces have been installed correctly.

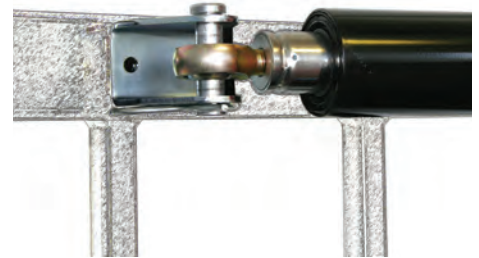

## Installing Gate Bracket to Gate for Push to Open configuration

Procedure is identical to the steps for Pull to Open except the gate will be in the fully closed position. For a push to open configuration, you will need to reverse the operating direction for the gate on the control board.

## 11 Preparing Sentry Control Box for Installation

The control box has two holes in the bottom of the box providing access to the wire compartment. The large hole is for the actuator cable and the smaller hole is for the charge device cable.

Install the provided cable gland into the small hole as shown here.



## 12 Install Sentry Control Box

The control box should be installed in a location that will not require the eight foot linear actuator cable to be spliced. If the cable must be spliced, refer to the splicing instructions below. The most common location would be on a fence or wall adjacent to your gate. Avoid placing the control box behind solid metal objects that might interfere with the receiver reception. The antenna for the receiver is located inside the control box and this could reduce the operating range.

1. Use control box as a template to determine and mark the mounting screw locations using the 4 mounting holes.
2. Drill mounting holes for screws **DO NOT ATTEMPT TO HOLD THE CONTROL BOX IN PLACE WHILE YOU DRILL THE MOUNTING HOLES.** This could damage the pre installed components.
3. Attach the 4 #12 hex head self tapping metal screws.
4. Mount the control box on the screws.

**Verify the structure the control box is mounted on is sufficient enough to hold the control box and battery securely.**



## Install Linear Actuator Cable

The linear actuator is supplied with 8' of cable. Care should be taken to protect the cable from damage that might be caused by animals, lawn equipment etc.

Route the cable into the control box bottom, snap in 1 ¼" plastic grommet.

**DO NOT plug into control board at this time.**

## 13 Splicing Linear Actuator Cable or Installing 2nd Linear Actuator Cable for Dual Gate System.

When adding an extension cable to a single gate actuator cable or when installing a second gate actuator for Gate 2, the 8 foot actuator cable must be cut and spliced in the following manner.

### Once actuator has been installed:

1. Locate the linear actuator 8 pin connector. Measure 18 inches from the connector end and cut the black cable. See Figure
2. Save this 8 pin connector and pigtail cable for step 8.
3. Install a rain tight junction box on the Gate 2 hinge post below or near the actuator.
4. Install the extension cable from the junction box at Gate 2 to the control box. Route the cable through the bottom of the junction box and the control box. Cut the cable longer than needed for future needs and ease of servicing.



**NOTE: The Dual Gate Opener system includes 50 ft of extension cable. If the distance between the junction box and the control box exceeds this distance it is recommended to purchase a cable that will not require additional splices in the cable. USAutomatic Part# 630010 can be custom ordered and purchased in any length. Never make underground splices as moisture in connections will definitely cause system malfunctions.**

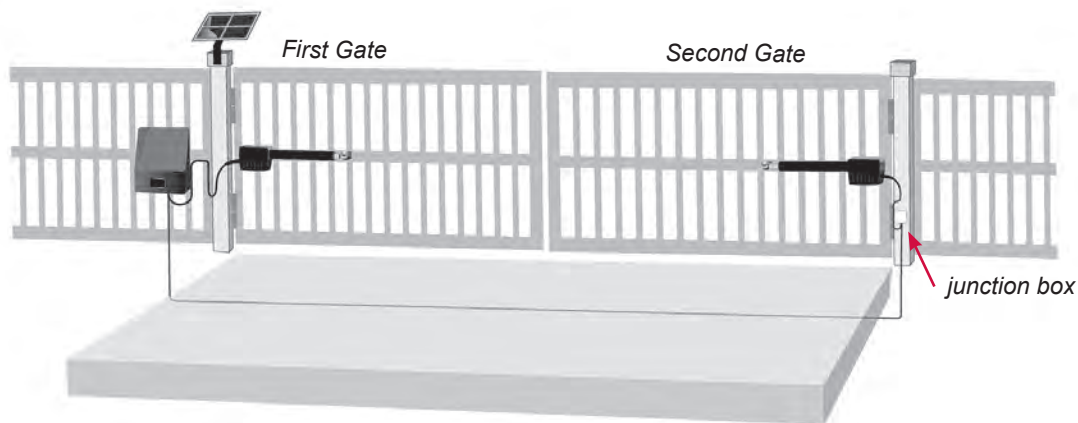

5. Route the linear actuator cable into the junction box through the bottom of the box and determine length. Allow ample slack in the cable for actuator movement when opening and closing the gate. Cut cable longer than needed for future servicing.
6. Remove at least 2 inches of the exterior black jacket on both cables routed into the junction box. Strip back approximately 1/2 inch of insulation from all wires. Connect the wires from each cable, matching color to like color with wire nuts. Pull firmly on all wires to be sure all connections are tight.
7. Install rain tight cover on junction box.
8. Remove at least 2 inches of the exterior black jacket on the pigtail cable (saved from step 2) and on the remaining end of the extension cable previously routed into the control box (step 4). Strip back approximately 1/2 inch of insulation from all wires. Connect the wires from each cable, matching color to like color with wire nuts. Pull firmly on all wires to be sure all connections are tight.
9. Do not plug into control board at this time.



**IMPORTANT: The length of the extension cable should be as short as possible.**

## 14 Installing Monitored Entrapment Protection Devices

When the installation requires more than 1 monitored contact edge or 2 monitored photo eyes, the Monitored Entrapment Device Expansion Module must be installed. (USAutomatic Part# 500015)

### 14a Monitored Photo Eye (Type BI) Installation for Entrapment Protection ONLY.

Connect wires per the table below: All wiring should be done with power disconnected from control board.

Photo Eye wiring for Entrapment Device Protection	
Photo Eye Connections	Sentry Control Board Connections
Power +12 vdc	J2 pin 12
Power ground / O	J2 pin 2 or pin 7
Common	J2 pin 2 or pin 7
N/C contact Closed Direction	J2 pin 8
N/C contact Open Direction	J2 pin 4

#### Wiring Photo Eyes to the Control Board

If being installed for close direction protection

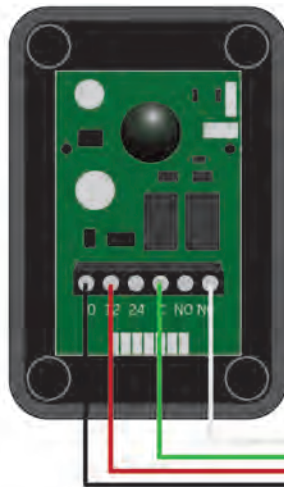

Photo eye "O" connects to J2 green plug pin 7.  
 Photo Eye "12" connects to J2 pin 12  
 Photo Eye "C" connects to J2 pin 7  
 Photo Eye "NC" connects to J2 pin 8



If being installed for open direction protection

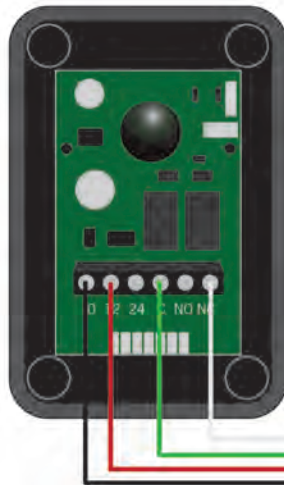
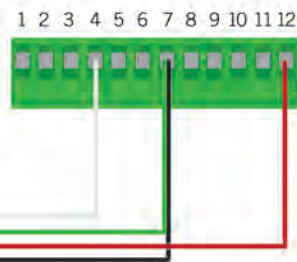

Photo Eye "NC" connects to J2 pin 4



The energy saving design of the control board will only apply 12 vdc to the photo eye when the gate is in operation. During installation +12 vdc power is required to align the photo eye beam.

Set control board SW1 dipswitches as follows for the installation:

Control Board Dipswitch Settings for Installation	
SW1 switch 3	OFF – press down on the left hand side
SW1 switch 4	OFF – press down on the left hand side
SW1 switch 10	ON – press down on the right hand side

Install the photo eye at this time. Once power is applied to the system, verify alignment. Step 21.

### **14b Monitored Contact Edge (Type B2) Installation** for Entrapment Protection ONLY.

Connect wires per the table below: All wiring should be done with power disconnected from control board. Contact edge must have 8.25K or 10K ohm resistor built into device.

Contact Edge wiring for Entrapment Device Protection	
Contact Edge Connectors	Sentry Control Board Connections
N/O connection	J2 pin 6
Common	J2 pin 2 or pin 7

### **14c Constant Pressure (Type D) Installation**

Connect wires per the table below: All wiring should be done with power disconnected from control board. The included warning placard must be installed by the control switch

Type D wiring for Emergency / Constant pressure Operation	
Constant Pressure Switch N/O type	Sentry Control Board Connections
N/O connection	J5 pin 1
Common	J5 pin 2



## 15 Install Battery

1. Install the battery into the battery compartment.
2. Connect ring terminals from harness to the battery.

NOTE: Red wire to positive post of battery  
Black wire to negative post of battery

**CAUTION:** Do not install wet cell battery into control box; This type of battery usually has removable caps used for service and will vent corrosive fumes into control box.



## 16 Install Power Source - DC Adapter or Solar Panel

The USAutomatic transformer (PN520009) is a low DC voltage UL approved transformer. The transformer is equipped with a DC plug for easy connection to the battery controller. In the event AC power goes out the opener will operate for weeks on the battery (if cycles per day are below 10) before needing service. Always use Solar Friendly accessories to help avoid premature battery failure incases of power outages.

**NOTE: 110 VAC receptacles should be installed by a qualified electrician, per local building codes.**



## 17 Solar Charged System

The solar option allows you to install the gate operator in remote areas or in applications where you prefer to be solar charged. Solar charging provides isolation from lightning that might damage the unit via the AC power needed for the transformer. The use of solar friendly accessories will help prevent premature battery failure.

The Solar model is designed to provide enough cycles a day for most installations without needing more than one solar panel. Care must be taken to ensure the solar panel has full sun throughout the day; partial sun will give partial results. If no sun is present then a solar system is not practical no matter how many panels might be installed. The solar panel must be kept clean and in full sunlight.

The location of the solar panel is critical for proper battery charging. The panel needs to face a South to Southwest direction and be installed at the angle of the supplied solar panel bracket. For proper operation the panel must have unobstructed sun. Even a small amount of shade will cause the Solar Panel to cease charging. Something as tiny as a fingertip shadow will affect the Solar Panel.

Solar panel may be moved up to 200 feet from the control box to achieve adequate sunlight. See power source cable extension chart Appendix A for proper wire size. For convenience use the USAutomatic 75' Cable Kit Part #520016.



See Region Map below to determine cycles that can be expected. These numbers are based on a basic system with the standard solar panel. Adding solar friendly accessories will not have any great affect on the numbers stated. Using other accessories can cause premature battery failure.



**GATE CYCLES PER DAY SOLAR CHARGED SYSTEM** (Optional Solar Kit PN #520026)

Model Type	ZONE 1	ZONE 2	ZONE 3
Sentry I Single Gate	30 cycles per day	50 cycles per day	75 cycles per day
Sentry II Dual Gate	16 cycles per day	28 cycles per day	50 cycles per day

Region 1 covers the area of the country receiving the least amount of solar radiation. On average the amount of charge time is 2.5 hours in region 1, 3.5 hours in region 2 and 5.5 hours in region 3.

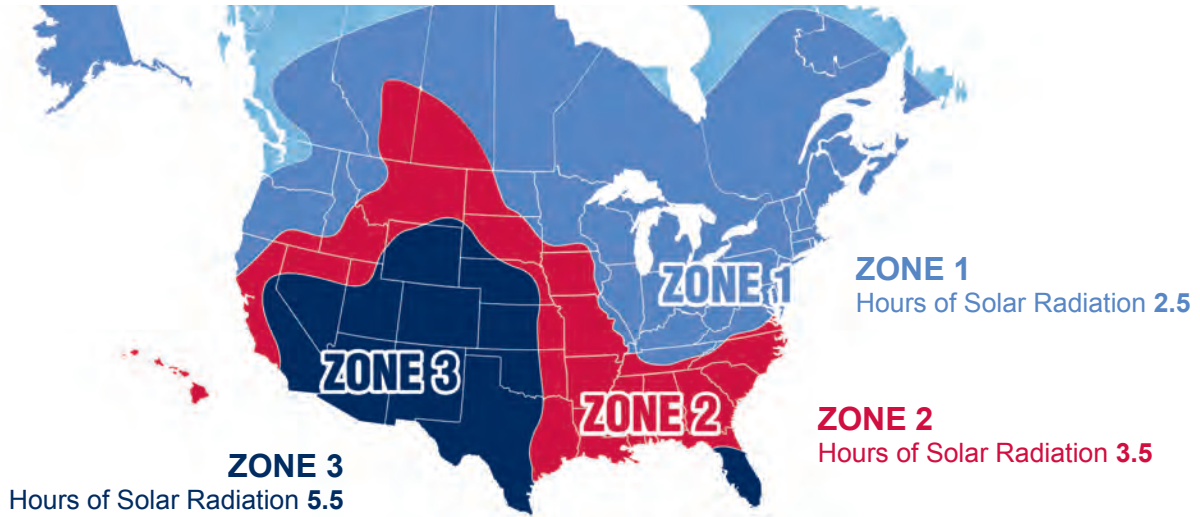

**Installing Power Source Cable into Control Box**

1. Loosen cable gland nut and route the cable from the power source into the control box (see figure). Ensure that DC plug can reach the battery controller connector.
2. Tighten cable gland nut to hold cable in place.

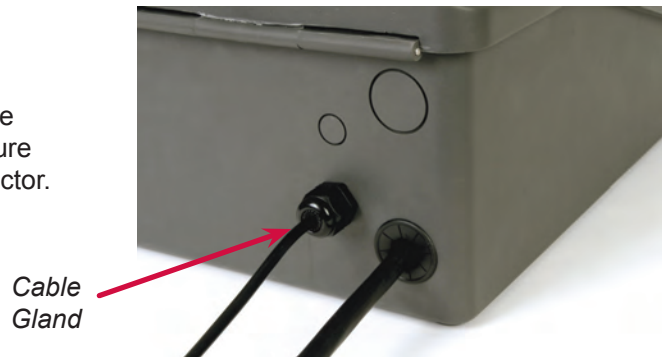

## 18 Connect Power Source to Battery Controller

(Transformer or Solar Panel Kit)

The battery controller accepts inputs from either the DC transformer or the solar panel. The transformer and solar panel come with a DC plug for easy installation. Once the charge device is selected and installed connect the DC plug into the battery controller.

If needed, use power source adapter supplied with controller.

**Once the power source is plugged into the battery controller verify the following:**

The LCD display is showing the battery voltage. If below 12 vdc charge battery first

The Solar panel to Battery arrow is displayed - indicates charging

Charge Device  
plugs in here



## 19 Sentry Plug N Go Harness Final Installation

**Verify the following items have been completed correctly before continuing. If necessary, correct before proceeding:**

- ✓ Linear actuator installation is complete.
- ✓ Control box is securely installed.
- ✓ Plug N Go harness is connected to the battery controller.
- ✓ Plug N Go harness is connected to the battery.
- ✓ Battery is installed in the battery compartment of control box.
- ✓ Power source cable is routed into control box and connected to the battery controller.
- ✓ Linear actuator cable is routed into control box.

**If completed, proceed with the following steps:**

1. Locate the power connector attached to the linear actuator cable (red and black wires).
2. Connect it to one of the Plug N Go harness linear actuator power plugs. These connectors are designed so that incorrect connection is not possible and it does not matter which connector is used.
3. Locate the linear actuator cable 8 pin plug.
4. Connect it to the Gate 1 connector located on the Sentry Control board.
5. Securely snap in place.
6. Once all connections are made place wires in wire compartment.

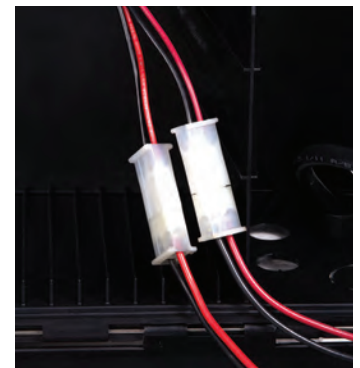
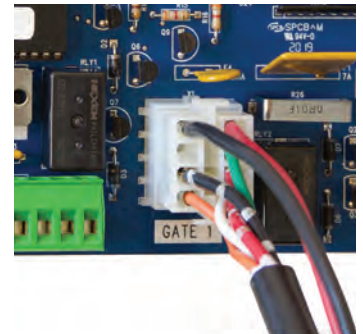

**This completes all cable connections and cable routing into the control box.**

## 20 Gate Delay

**Sentry II (Dual Gates)** with overlapping gates or electrical lock requiring gate delay.

When the electric gate lock dipswitch is turned ON the gate connected to Gate 2 will delay on an open command and close first on a close command, the delay is 1.5 seconds.

## 21 Photo Eye Alignment

Plug the J2 accessory plug into the control board at this time.

Set SW1 dip switches as follows for alignment

- SW1 switch 3 and 4 OFF
- SW1 switch 10 ON

With power now applied the photo eyes can be aligned, Verify alignment and adjust as necessary.

For detailed instructions refer to the installation instructions included with the photo eye.

## 22 Install Safety Signs

Install the 2 warning placards in the gate area where they are visible from the inside and outside of the gate. These are required per UL 325 to make persons aware of the possible danger of an automated gate.



## 23 Operating Gate for the First time

Identify your installation below and verify the correct SW1 dipswitch settings.

**NOTE:** This check must be performed before operating the gate. Failure to do so may damage the gate operator.

Before operating the gate lets make sure the control board dipswitches are set correctly for your installation. Locate the SW1 dipswitches on the control board.

Factory SW1 default dipswitch settings are 3 and 4 ON.

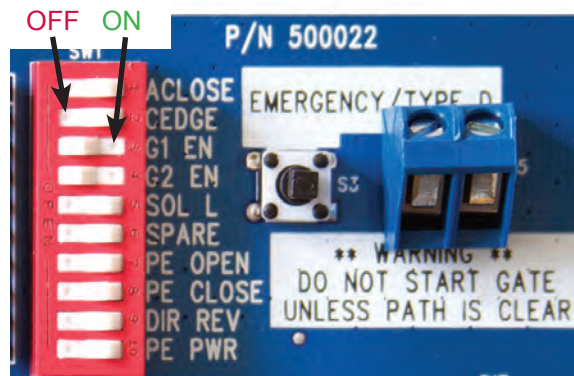

ON - Down on right  
OFF - Down on left

		SW1 switch settings	Photo Eye Close Direction	Photo Eye Open Direction	Contact Edge
<b>Single</b>	(PULL TO OPEN)	SW1 switch 3, 4 should be in the ON position	SW1 switch 8 and 10 ON	SW1 switch 7 and 10 ON	SW1 switch 2 ON
<b>Single</b>	(PUSH TO OPEN)	SW1 switch 3,4 and 9 should be in the ON position	SW1 switch 8 and 10 ON	SW1 switch 7 and 10 ON	SW1 switch 2 ON
<b>Dual</b>	(PULL TO OPEN)	SW1 switch 3, 4 should be in the ON position	SW1 switch 8 and 10 ON	SW1 switch 7 and 10 ON	SW1 switch 2 ON
<b>Dual</b>	(PUSH TO OPEN)	SW1 switch 3, 4, 9 should be in the ON position	SW1 switch 8 and 10 ON	SW1 switch 7 and 10 ON	SW1 switch 2 ON

1. Locate the Open / Close command button on the control board. This button will start the gate when pressed once; pressing it again will stop the gate.
2. Press and release the Open / Close button. The linear actuator should begin to extend. Allow the gate to travel to the factory adjusted extend position. The gate should typically stop short of the desired extended position.
3. Press and release the Open / Close button twice. The linear actuator should begin to retract. Allow the gate to travel to the factory adjusted retract position. The gate should typically be very close to the desired retracted position. If minor adjustment is required remove release pin and rotate the threaded end rod to the desired open position.

**NOTE:** In case of an emergency, the Gate 1 or Gate 2 connector can be removed at anytime from control board to stop gate from moving.

## 24 Limit Adjustments

The control board limit adjustments are simple and easy to use. Control board has 4 adjustment dials for adjusting the desired stop positions.

The nudge procedure below can be used to easily adjust the extend limit ONLY. If adjustment is made and the extension tube is adjusted past the desired extend position you must reduce the extend limit adjustment so that the gate extends and stops short of the desired position. Then readjust extend limit following the nudge procedure.

Close and Open Limit Adjustments

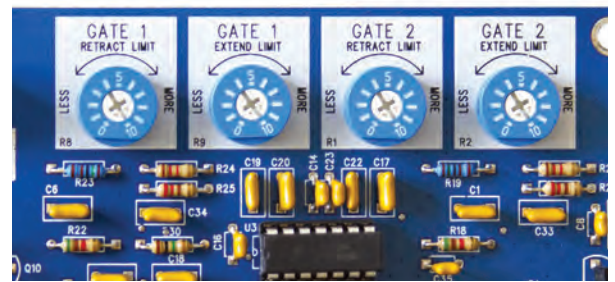

### Nudge Procedure

#### Single Gate Limit Adjustment

1. Connect the linear actuator cable for gate 1 only to the gate 1 port on control board.
2. Verify that both gate 1 and gate 2 dip-switches are turned ON, press down to the right hand side.
3. Press the open/close button on the control board allow actuator to fully extend.
4. Locate the gate 1 extend adjustment and turn clockwise slowly. The actuator will begin to extend as the adjustment is turned. Adjust until gate is in desired position. Avoid over extending.
5. Limit adjustment is complete. If a dual gate system continue with steps 7-12 below.
6. Turn OFF the gate 1 or gate 2 dip switch that is not being used.

#### Dual Gate Limit Adjustment

7. Disconnect the gate 1 actuator from control board.
8. Connect the linear actuator cable for gate 2 to the gate 2 port on control board.
9. Press the open/close button on the control board allow actuator to fully extend.
10. Locate the gate 2 extend adjustment and turn clockwise slowly. The actuator will begin to extend as the adjustment is turned. Adjust until gate is in desired position. Avoid over extending.
11. Limit adjustment is complete
12. Connect gate 1 linear actuator to the gate 1 port on control board.



Extend



Retract

## 25 Sensitivity Adjustment and Entrapment Alarm and Auto Close Setting

The control board has 2 sensitivity adjustment dials located on the left side of the control board. These adjustments control the amount of current the control board will allow the motor to draw from the battery to operate your gate. Minimum force is the least amount of current allowed. This circuit is inactive for the first second of gate operation.

Both sensitivity settings should be individually adjusted on dual gate systems. On single gate systems, adjust the setting for the actuator plug being utilized (Gate 1 or Gate 2) and then match the setting on the other sensitivity adjustment.

### Entrapment alarm:

The entrapment alarm installed gives an audible alert whenever the gate sensitivity feature is activated twice before gate reaches an open or close limit. See chart step 26 for operation. Also used for low battery audible notification.

### Auto Close Setting:

**Important:** Auto close should not be utilized unless safety devices are installed to prevent automatic operation in case an object is in the path of the gate. See appendix A.

The adjustment dial controls the auto close time from approximately 2 seconds to 150 seconds. A setting of 0 will be the fastest auto close time.

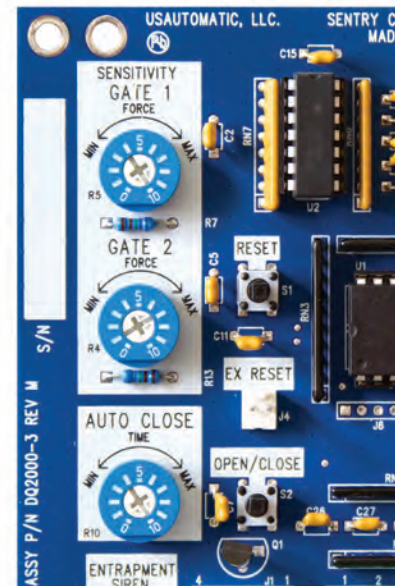

## 26 Verifying Inherent Entrapment Protection System (Type A) Operation:

Once the gate operator is installed use the table below to determine correct operation.

It is recommended that the current sensitivity adjustment for the gate being tested be set at a setting no greater than 5 when performing this test.

Gate Opening - Gate is stopped by an object after 1 second of operation	Gate Closing - Gate is stopped first time by an object after 1 second of operation
<ul style="list-style-type: none"> <li>Gate stops and reverses for ~ 2 seconds.</li> <li>Auto close if turned ON is disabled.</li> <li>Requires a Push Button, Close, Open or Reset input before normal operation resumes.</li> </ul>	<ul style="list-style-type: none"> <li>Gate stops and reverses to full open.</li> <li>Auto close if turned ON is disabled.</li> <li>Requires a Push Button, Close, Open or Reset input before normal operation resumes.</li> </ul>
Gate Closing after above obstruction – If Gate is stopped a second Time Before Reaching the Close Limit	Gate Opening after above obstruction – If Gate is stopped a second Time Before Reaching the Open Limit
<ul style="list-style-type: none"> <li>Gate stops.</li> <li>Alarm sounds for 5 minutes until Reset is pressed.</li> <li>Requires a Reset input before normal operation resumes.</li> </ul>	<ul style="list-style-type: none"> <li>Gate stops.</li> <li>Alarm sounds for 5 minutes until Reset is pressed.</li> <li>Requires a Reset input before normal operation resumes.</li> </ul>

## 26a Verifying Monitored Photo Eye (Type B1) Entrapment device Operation Only:

Operate the gate and verify entrapment protection devices are working properly.  
Use the table below to determine correct operation.

Type B1 - Photo Eye 2 <sup>nd</sup> Entrapment - N/C input J2 pin 4 - Open Direction If SW1 switch 7 is OFF this input is ignored. If ON, functions as described below	Type B1 - Photo Eye 2 <sup>nd</sup> Entrapment - N/C input J2 pin 8 - Closed Direction If SW1 switch 8 is OFF this input is ignored. If ON, functions as described below
<b>Gate Opening Photo Eye Activated</b>	<b>Gate Closing Photo Eye Activated</b>
Gate stops	Gate stops and reverses to full open
Auto close if turned ON is still active	Auto close if turned ON is still active
Return to normal operation when the sensor is no longer activated.	Return to normal operation when the sensor is no longer activated.

## 26b Verifying Monitored Contact Edge (Type B2) Entrapment device Operation Only:

Contact Edge (Type B2) Monitored Entrapment N/O input J2 pin 6 If SW1 switch 2 is OFF then gate will not move. If ON, functions as described below.	
<b>Gate Opening Edge Activated 1<sup>st</sup> time</b>	<b>Gate Closing Contact Edge Activated 1<sup>st</sup> Time</b>
Gate stops and reverses for ~ 2 seconds	Gate stops and reverses to full open
Auto close disabled	Auto close if turned ON is still active
Requires a Push Button, Close or Open input before normal operation resumes.	<b>If while opening after reversal above, a 2<sup>nd</sup> sequential input is received, gate must stop</b>
<b>If while closing after reversal above a 2<sup>nd</sup> activation occurs before the 2 seconds then</b>	Requires a Push Button, Close or Open input before normal operation resumes.
Gate stops	<b>Gate Closing Edge Activated 2<sup>nd</sup> Time before the close limit then</b>
Auto close disabled	Gate stops
Requires a Push Button, Close or Open input before normal operation resumes.	Auto close disabled
	Requires a Push Button, Close or Open input before normal operation resumes.

## 26c Verifying Constant Pressure (Type D) Operation Only:

**IMPORTANT:** Verify the gate path is clear before pressing the S4 button.

The S4 push Button (N/O) requires constant pressure to operate gate. When pressed and held the gate will run until the limit is reached or the button is released. If the button is released in mid travel the gate will stop and the next press of the button will run the gate in the opposite direction.

IF gate is closed and emergency switch is activated the gate will open and remain open until deactivated.



## 27 Sentry Control Board Information

The Sentry control board is capable of operating two gates. If your installation is a single gate you can operate the gate on the Gate 1 or Gate 2 connector. Set control switch “ON” for the connector being used.

Type D push button requires constant pressure for gate operation. The user must verify the gate path is clear before pressing the button to operate gate.

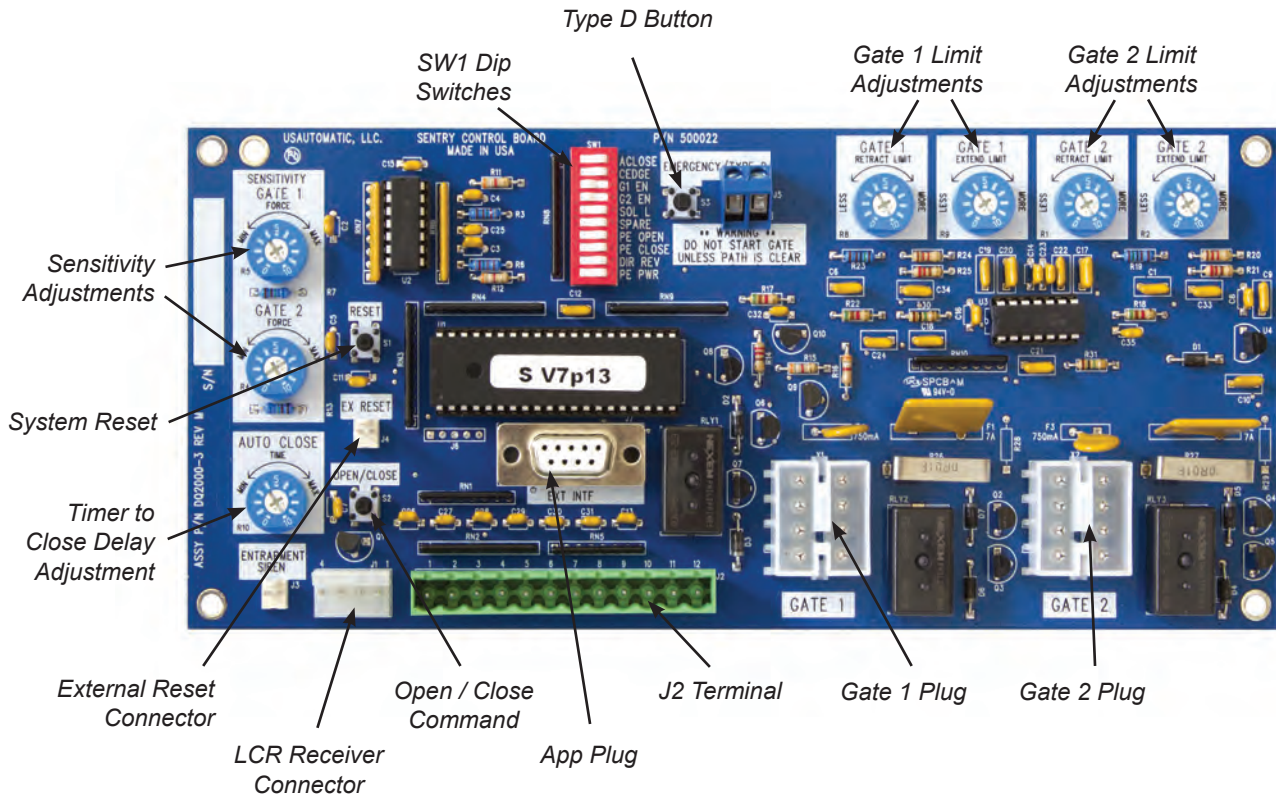

1. The “Open / Close Command” push button can be used to operate gate if all entrapment devices are functioning properly.
2. The second feature is the S4 push button - Type D protection - This button makes it possible to operate the gate with the J2 Accessory plug removed. Type D button will bypass all entrapment devices allowing gate operation. Verify gate path is clear before pressing button. Must hold button for gate operation.
3. Low battery Audible notification - If the battery voltage falls below 10.5 vdc the siren will beep 3 times rapidly pause 5 seconds and repeat for 60 seconds. The next time the gate is operated this will repeat until the battery problem is corrected.

## J2 Terminal Description

The accessory connector is a plug which can be removed from the control board for ease of wiring and troubleshooting purposes.

Pull out to remove.

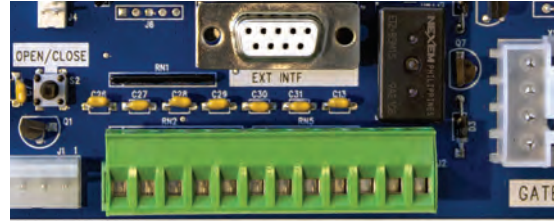

J2 Terminal

Terminal	
1	+12 vdc Output <i>(Maximum current output 750 milliamps)</i>
2	Common Ground
3	Push Button Input <i>(normally open contacts)</i> <i>(Push button, radio control, keypad, etc.)</i>
4	Photo Eye Open Direction N/C Input <i>SW1 Switch 7 must be on. No 10K resistor.</i>
5	Electric Gate Lock output +12 vdc
6	Contact Edge N/O (with 10K resistor) connection monitored entrapment <i>SW1 switch 2 must be ON when monitored edge is connected</i>
7	Common Ground Input
8	Photo Eye Closed Direction N/C Input <i>SW1 Switch 8 must be on. No 10K resistor.</i>
9	Free Exit / Open Input <i>(normally open contacts)</i> <i>Loop input or any hold open input such as a 7-day timer, telephone access unit, or maintain contact switch (normally open contacts). These devices open the gate and will prevent the gate from closing if the contact is maintained. Once the contacts have been released, the gate can be closed with a closed signal device or the automatic close timer feature. Receiver relay2 pre-wired for latching open.</i>
10	Not Used
11	Safety Loop / Photo-eye / Reversing Edge Input used for vehicular protection devices. <i>(normally open contacts) *No 10K resistor - remove if installed</i>
12	Photo Eye Power +12 vdc output 750 ma max current <i>Only present when SW1 switch 10 is ON and gate is moving or SW1 switch 3 and 4 are OFF and SW1 switch 10 is ON used for installation.</i>

## SW1 Function Dip Switches

ON - Down on right

OFF - Down on left

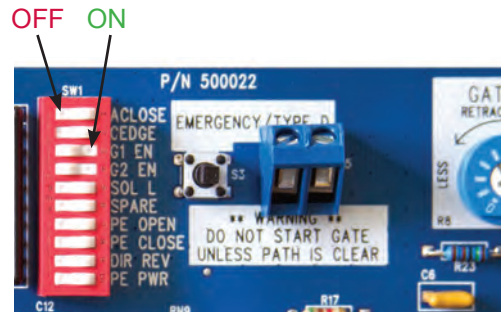

Switch		Setting	Factory Settings are shown in bold type
1	Automatic Close Timer Enable <i>(Not recommended unless safety devices are installed)</i>	ON	Timer to close is activated
		<b>OFF</b>	<b>Timer to close is disabled</b>
2	Contact Edge Monitored	ON	Monitored contact edge is installed. Contact Edge must have 8.25K or 10K resistor.
		<b>OFF</b>	<b>No monitored Contact Edge installed</b>
3	Gate 1 Enable	<b>ON</b>	<b>Gate 1 operator enabled to function</b>
		OFF	Gate 1 operator disabled
4	Gate 2 Enable <i>(both gates on for dual)</i>	<b>ON</b>	<b>Gate 2 operator enabled to function</b>
		OFF	Gate 2 operator disabled
5	Electronic Gate Lock Solenoid Type	ON	Electric Gate Lock Enabled
		<b>OFF</b>	<b>Electric Gate Lock not activated</b>
6	Not Used	ON	
		<b>OFF</b>	
7	Photo Eye Open Only N/C Monitored Entrapment	ON	Monitor Photo Eye open direction only
		<b>OFF</b>	<b>No monitored Photo Eye open direction installed</b>
8	Photo Eye Closed Only N/C Monitored Entrapment	ON	Monitor Photo Eye closed direction only
		<b>OFF</b>	<b>No monitored Photo Eye close direction installed</b>
9	Operating Direction Reverse <i>(Must be on for push to open installations to operate correctly)</i>	ON	Push to Open
		<b>OFF</b>	<b>Pull to Open</b>
10	Photo Eye Power Management Enable <i>*when ON 12 vdc will be present at J2 pin 12 whenever gate is in motion.</i>	ON	Enables PEPM
		<b>OFF</b>	<b>Disables PEPM</b>

## 28 Programming Transmitter and Receiver

Operating frequency 433.92 MHz.

Receiver can store up to 42 unique transmitter dipswitch code settings.

### Transmitter Setup:

*(It is recommended that the dipswitch code be changed from the default factory setting)*

1. Open the battery compartment door and locate the dipswitches.
2. Change the dipswitches to the settings you prefer, record for future reference in the table below.

Switch Position	Switch 1	Switch 2	Switch 3	Switch 4	Switch 5	Switch 6	Switch 7	Switch 8	Switch 9
+									
0									
-									



### Transmitter Left Button to Receiver Programming: (standard Open/Stop/Close function)

1. Press and hold the left transmitter button down. Red light on transmitter should be on.
2. On the receiver, push the P1 push-button until the green LD light comes on.
3. Release both buttons. Transmitter left button to receiver programming is complete.

### Transmitter Right Button to Receiver Programming: (Hold-Gate-Open)

1. The 2-channel receiver allows for programming the P2 relay from momentary mode (default) to latching mode. Transmitter right button can be programmed to hold gate open, over-riding the auto-close or any other close command.
2. Press and hold the right transmitter button down. Red light on transmitter should be on.
3. Press the P2 push-button until the green LD light comes on.
4. Release both buttons. Transmitter right button to receiver programming is complete.

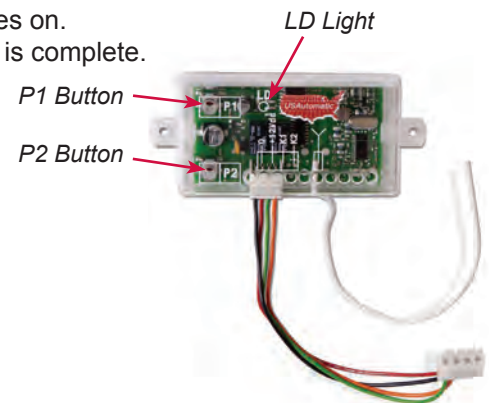

### Receiver Programming: Relay P2 programming from momentary to latching mode (to hold gate open)

See Receiver Programming on page 42 to complete Hold-Gate-Open programming.

### Erasing Single Transmitter from Receiver Memory:

The dipswitch settings of the transmitter to be deleted must be known. If known follow the steps below.

1. Set the dipswitches in a transmitter to match the switch settings of the transmitter code to delete.
2. Press and hold the left transmitter button.
3. On the receiver, push the P1 push-button until the green LD light comes on. Then release both.
4. Press and hold the right transmitter button.
5. On the receiver, push the P2 push-button until the green LD light comes on. Then release both.
6. Transmitter is now erased from receiver memory.

### Erasing all Transmitters from Receiver Memory:

1. Press the P2 button on the receiver until the green LD light comes on. Then release P2 button.
2. While LD light is on press the P1 and P2 buttons simultaneously and hold until the green LD light begins to blink slowly. It should blink 4 times then all transmitter codes are erased.

# Programming Your Wireless Keypad

**050520 or  
050500** (plastic)



PUK code

\_\_\_\_\_

**050551**  
(metal)



PUK code

\_\_\_\_\_

## Terms to Understand

**Access Code** – The 2 to 5-digit code used to open the gate (24 unique codes are possible). If access code is less than 5 digits it requires the # sign after code is entered. Example: “2 #.” If code is 5 digits the # sign is not required. Metal keypad uses A or B in place of \* and #.

**ACCESS CODE CAN NOT BE THE SAME AS THE MASTER PASSWORD.**

**Master Password** – The 5-digit code used to access programming features. Factory default is “11111”. This should be changed for security reasons.

**NOT USED TO OPEN GATE AND CAN NOT BE THE SAME AS THE ACCESS CODE.**

**Relay 1** – The receiver has 2 relays. P1 (relay 1) is pre-wired to the J2 connector - pin 3.

**Relay 2** – The receiver has 2 relays. P2 (relay 2) is pre-wired to the J2 connector - pin 9.

**Keypad Security Code (Dip Switch Code)** – This code makes your keypad unique to your installation. Keypad does not have dip switches like the transmitter; instead it has virtual dip switches which must be programmed.

**PUK Code** – “Password Unblocking Key.” The PUK code is located inside the keypad and is needed when the master password has been lost. Record in space above for future reference. Must be 5 digits long.

**“ \* ” or “A” Key** – located on the keypad is used to cancel last command entered.

**Red Light Blinks** – When blinking, the keypad is sending a signal to the receiver. Valid access code was entered. This is the Blue 5 key on the metal keypad.

**NOTE: Do not install keypad until “Create Communication with Receiver P1 (relay 1)” has been completed.**

## Keypad Programming

**Create Access Code:** (Code you use to operate the gate)

**\*CAN NOT BE THE SAME AS THE MASTER PASSWORD!**

1. Enter the Master Password “11111”. (this is the factory default master password).
2. Enter “9” If correct, 2 short beeps (if 1 long beep is heard, start over with step 1).
3. Enter the new Access Code (up to 5 digits), if less than 5 digits, “# or B” key is required.
4. Enter “9”
5. Enter the new Access Code again to verify.
6. Enter “1”. If this access code is for P1 (relay 1) Enter “2” if this access code is for P2 (relay 2).
7. If correct, 2 short beeps (if 1 long beep is heard, start over with step 1).
8. Continue with “Create Communication with Receiver” to complete programming.

**NOTE:** Step 6 above allows you to select a unique frequency (1, 2, 3, 4) for the access code you are creating. Keypad can be programmed with 4 different access codes each having a unique frequency. This is used when multiple gates are within range of the keypad. Create an access code using 1 in step 6 for one gate. Create an access code using 2 in step 6 for the second gate. This allows one keypad programmed with 2 access codes to operate 2 different gates within range or two keypads can be installed on 2 different gates without interfering with each other. If 4 gates were involved then 3 and 4 could be used in step 6. Also used to create a unique access code to activate the hold open feature offered with P2 (relay 2).



**Create Communication with Receiver: \*for P1 (relay 1) access code:**

1. Carry keypad to receiver location for programming.
2. Enter Access Code for P1 (relay 1) on the keypad and continue to hold the last key entered (red light blinks).
3. Press P1 (learn button) on the receiver until LD (green light) comes on and relay clicks.

Receiver

P1 Button

P2 Button

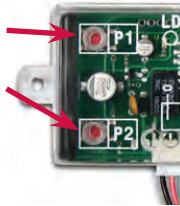

**Create Communication with Receiver: \*for P2 (relay 2) access code:**

1. Carry keypad to receiver location for programming.
2. Enter Access Code for P2 (relay 2) on the keypad and continue to hold the last key entered (red light blinks).
3. Press P2 (learn button) on the receiver until LD (green light) comes on and relay clicks.

**Programming New Master Password: Once created record here for reference \_\_\_\_\_**

**NOTE: The Master Password is NOT an access code. This is a MASTER programming code used to access the programming of the keypad. It is not used to operate the gate.**

1. Enter the Master Password "11111".
2. Enter "8" If correct, 2 short beeps (if 1 long beep is heard, start over with step 1).
3. Enter the Master Password (up to 5 digits), if less than 5 digits, "# or B" is required.
4. Enter "8"
5. Enter the Master Password again to verify.
6. Press "8" If correct, 2 short beeps - New Master Password is set (If 1 long beep is heard, start over with step 1).

**Programming Master Password Back to Factory Default: (11111)**

1. Enter "11111".
2. Press "8" (long beep).
3. Enter PUK code. (PUK must be 5 digits).
4. Press "8".
5. Enter PUK code to confirm.
6. Press "8" (2 beeps) Master password reset complete.

**Deleting Single Access Code:**

1. Enter the Master Password.
2. Press the "7" key. If correct, 2 short beeps (*if 1 long beep is heard, start over with step 1*).
3. Enter the Access Code to be deleted.
4. Press the "7" key. (*cont. next page*)
5. Reenter the Access Code to be deleted.
6. Press the "7" key. If correct, 2 short beeps (*if 1 long beep is heard, start over with step 1*).

**Deleting All Access Codes:**

1. Enter the Master Password.
2. Press the "7" key. If correct, 2 short beeps (*if 1 long beep is heard, start over with step 1*).
3. Reenter the Master Password.
4. Press the "7" key.
5. Reenter the Master Password.
6. Press the "7" key. If correct, 2 short beeps (*if 1 long beep is heard, start over with step 1*).

## Changing Keypad Security Code:

This keypad has a virtual dipswitch used to create your Security Code. The virtual dipswitch contains nine 3-position switches. To ensure neighboring keypads do not interfere with each other, the virtual switches should be positioned in a random pattern, using the following procedure.

Example of random positioning of the virtual dipswitches to create a Security Code is shown below. To enter the Security Code, enter the dipswitch number, followed by the dipswitch position character.

The Security Code would be entered as: 1# 20 3\* 4\* 5# 6\* 7# 80 9\*

Dipswitch Position	Switch 1	Switch 2	Switch 3	Switch 4	Switch 5	Switch 6	Switch 7	Switch 8	Switch 9
# or B	X				X		X		
0		X						X	
* or A			X	X		X			X

Use table below to create your random security code and follow steps below to program your keypad.

Dipswitch Position	Switch 1	Switch 2	Switch 3	Switch 4	Switch 5	Switch 6	Switch 7	Switch 8	Switch 9
# or B									
0									
* or A									

1. Enter the Master Password.
2. Enter "6" If correct, 2 short beeps (if 1 long beep is heard, start over with step 1).
3. Enter the Security Code created in the previous table. If correct, 2 short beeps after each switch number and switch position combination is entered.
4. Enter "# or B"
5. Enter "6"
6. If correct, 2 short beeps (if 1 long beep is heard, start over with step 1).

## Receiver Programming - Hold Gate Open

### Relay P2 programming from momentary to latching mode (to hold gate open)

1. Press the P2 push-button until the green LD light comes on, then release.  
*Green LD light should be steady. If flashing latch mode is already set.*
2. If not flashing release P2 immediately and press P1 once.
3. Green LD light should be flashing. Latching mode is set.

### Verifying Receiver P2 relay is programmed to latching mode:

1. Press the P2 push-button until the green LD light comes on, then release.
2. Green LD light should be flashing. If green LD light is steady, redo the Receiver Programming section above.

### Resetting receiver P2 relay to momentary mode:

1. Press the P2 push-button until the green LD light comes on, then release. Green LD light should be flashing.
2. While the LD light is flashing, push the P1 push-button down and release. Green LD light should be steady. Momentary mode is set.



## 29 Emergency Manual Release

Remove the manual release pin at the gate bracket and open the gate by hand. Secure the gate before attempting to pass through.

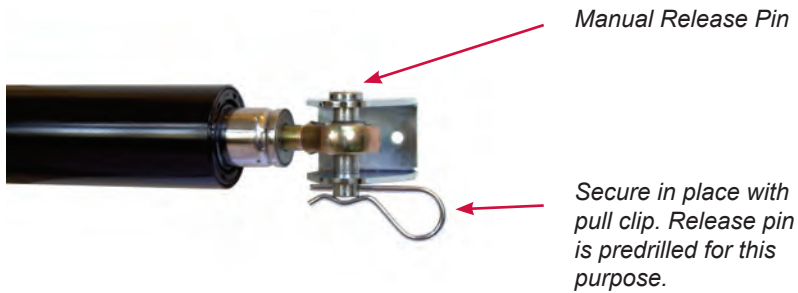

## PERIODIC SERVICE

All gate operators require periodic checking and adjustments of the control mechanism for force (load), speed and sensitivity.

All accessories and monitored safety devices must be checked. Monitored protection devices need to be checked at least once a month for proper operation.

Periodic checking is also advised for the following:

1. Battery terminals for corrosion, clean as required.
2. Hinges and pivot points need to be greased.
3. Mounting bolts for correct tightness.
4. Inspect weld points for cracks or other defects.
5. Inspect wiring for cuts, nicks or other defects.
6. Inspect hinge post to ensure it is not moving or twisting.
7. Verify monthly that the inside of the control cabinet remains clean and free of insects. Do not spray control board with bug spray or oil based products.
8. Observe battery controller and verify battery voltage reading is above 11 vdc. If not have battery load tested.



## Accessories

### Electric Gate Lock

Part Number 070510

#### Suitable for solar and AC charged systems.

The Patriot Control Board will energize and release a 12 vdc electric gate lock or de-energize and release a magnetic gate lock 1 second before the gate or gates begin to open.

#### To activate the electric gate lock delay circuit

Turn DS2 switch 1 on. This also activates the Gate Delay Feature on Dual Gate systems.

Connect the ground wire from the gate lock to the negative battery post.

Connect the positive (+12vdc) wire from the gate lock to J1 Solenoid Lock terminal.

For Dual Gates, see Gate Delay Feature Section, pg 25.



### 20 Watt Solar Panel

Part Number 520030

15 foot cable

2 mounting brackets included

DC power plug for easy connection



### Exit Sensor (Solar friendly device)

Preferred Technologies CP-4

Part Number 070310

The driveway exit sensor is a magnetic device that installs below ground beside the drive. A magnetic field is established which when interrupted by a moving metal object will send a signal to open the gate. This sensor is supplied with a 100 foot cable and is typically installed inside the property beside the drive to automatically open the gate when a car passes. This type of sensor is not a safety device.

Sensor can be ordered with longer cable lengths that fit the installation. (Standard 100')

Install cable in PVC conduit.

Wire as follows: Red wire – connect to J2 pin 1

Black wire – connect to J2 pin 2 or pin 7

White wire – connect to J2 pin 2 or pin 7

Blue wire - connect to J2 pin 9 (Free Exit / Open Input)



## Push to Operate Wireless Button

Part Number 030215

The Push to Operate transmitter is designed for indoor or outdoor wireless installation. Install to allow operation of the gate or garage by simply pressing the pad. The button is a pressure sensitive pad. Press the pad and an audible tone is generated. Programming is identical to transmitter programming. Installation hardware is included. Compatible with all USAutomatic receivers.



### Programming Push to Operate

1. Install battery
2. Press & Hold receiver P1 until Green LED illuminates
3. Immediately place hand on face plate (while Green LED is lit)
4. When gate operates, programming is complete.

## 2 Button LCR Transmitter

Part Number 030210

Standard Transmitter for all USAutomatic operators

Operating Frequency 433.92 MHz



## 4 Button LCR Transmitter

Part Number 030212

Operating Frequency 433.92 MHz



## Monitored Entrapment Device Expansion Module

Part Number 500015

The expansion module is designed to monitor for the connection and proper operation of multiple monitored external entrapment devices.

If the installation requires more than 2 monitored contact edges or 1 monitored photo eye for open or close direction, the expansion module must be installed.

Monitors up to 5 monitored contact edges (10K resistor) and up to 4 monitored photo eyes (N/C contact - NO 10K) for a total of 9 devices.



## 7 Day Timer (Solar friendly device)

Part Number 550015

The optional 7 day timer can be used to open the gate at a preset time and if the auto close feature of the gate operator is being used the gate can then close automatically at a preset time. The timer is supplied with 3 spade terminals for easy connection. Wire not Included, 18-20 gauge braided wire recommended.

Connect wires from timer to control board J2 connector as follows:

- J2 Pin 1 (+12vdc) connect to pin 1
- J2 Pin 2 (Gnd) connect to pin 2
- J2 Pin 9 (Normally Open) connect to pin 4



## Nexx Gate App

Part Number 030223

### USAutomatic Nexx Gate smart phone app.

For operation of all USAutomatic gate operators from Wifi and Bluetooth. This weather-resistant companion device works with all USAutomatic gate openers equipped with the latest UL 325 obstruction sensing devices. The Nexx Gate App allows up to eleven users to securely open, close, and monitor their gate from anywhere in the world.



### Installing the Nexx Gate APP receiver to the Control Board

The USAutomatic NEXXGATE receiver module connects to the J8 plug on the control board.

Follow the instructions included with the NEXXGATE receiver for setup.

For solar charged systems a 20 watt panel is recommended part #520030

## Sentry External Antenna Kit

Part Number 030230

### Includes:

- \* 12V LCR receiver with Coax F-Connector
- \* 12' Coax Cable
- \* External Antenna
- \* External Antenna Bracket



# NEW Premium Wireless Keypad



Low Illumination  
Night Light

Large 1/2 Inch  
Stainless Keys with  
Blue Backlit Keypad

Mounts to  
Gooseneck post.

**SOLAR  
FRIENDLY**



Part number:  
050551

## USAAutomatic is proud to announce the sale of our NEW Premium Wireless Keypad.

This rugged, metal companion device is weather-resistant and works with all gate openers equipped with a USAAutomatic receiver. Power can be supplied with the included CR123 internal battery or hard wired to a 12 Vac/Vdc source. Battery life ~30 months and optional 2nd battery may be installed.

### Features Include:

- Rugged Die-Cast Locking Aluminum Cover
- 256 Access Codes
- 256 Temporary Access Codes programmable for 1 to 9 uses
- Hold Open access code
- Radio Transmission 433.92 mhz
- Keypad locks out for 60 seconds after 7 incorrect access codes

# Troubleshooting Guide

The complete troubleshooting guide is available online which allows us to easily and quickly update the contents as required.

Scan the QR code here with your phone camera to access the troubleshooting information online. Or visit - [www.usautomatic.com/troubleshooting](http://www.usautomatic.com/troubleshooting)



## Introduction

The Sentry control board features to assist in troubleshooting a gate system.

1. The on board "Open / Close Command" push button.
2. The S4 push button - Type D protection - This button makes it possible to operate the gate with the J2 Accessory plug removed. Type D button will bypass all entrapment devices allowing gate operation. Verify gate path is clear before pressing button. Must hold button for gate operation.
3. Low battery Audible notification - If the battery voltage falls below 10.5 VDC the siren will beep 3 times rapidly pause 5 seconds and repeat for 60 seconds. The next time the gate is operated this will repeat until the battery problem is corrected.

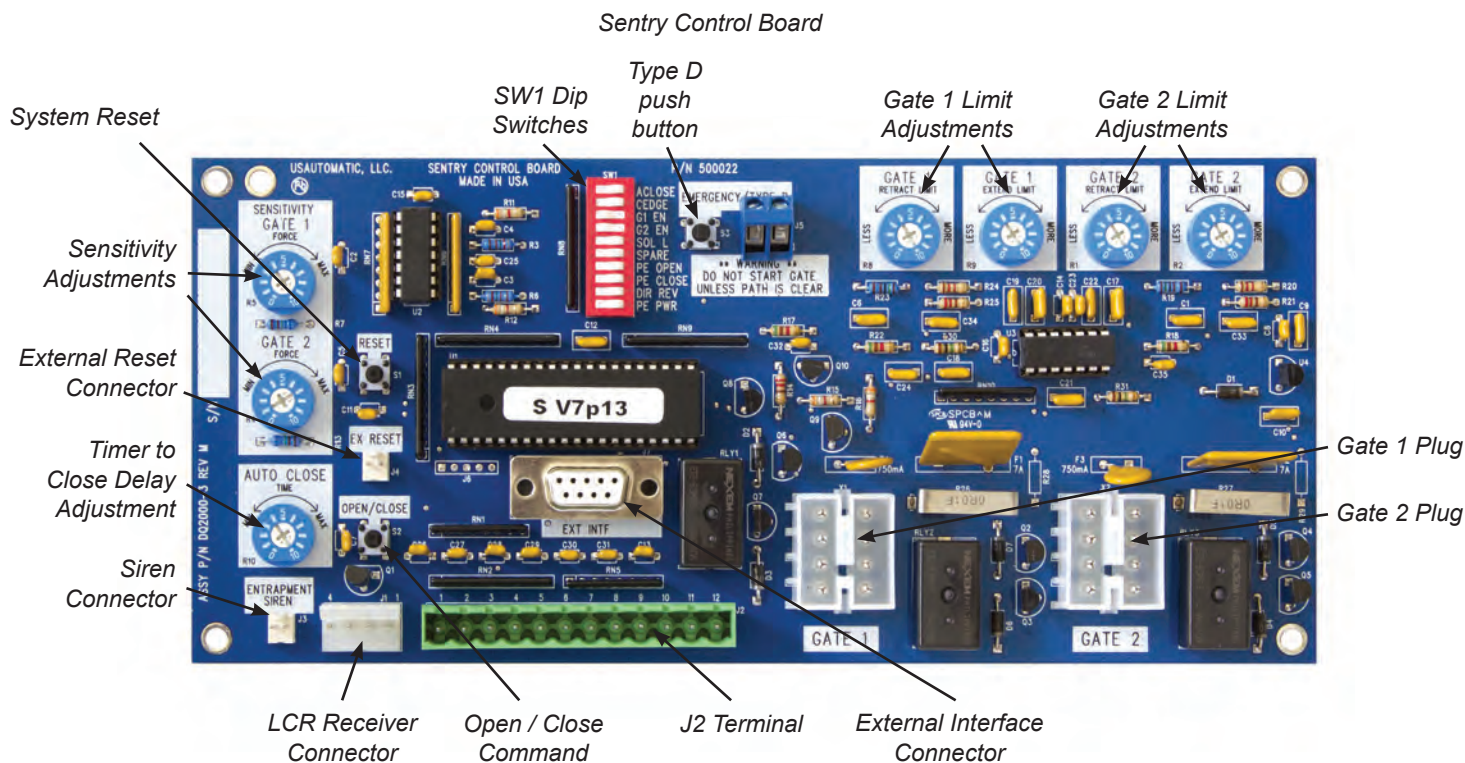

# Appendix

## **A** Photo Eye - Vehicular Protection Only

Part Number 550011 - battery or hard wired transmitter

Wiring Photo Eye to control board  
(Control Board part #500022)

Photo eyes are recommended for all systems. This provides protection against the gate closing on objects that may be in the gate path. Typically a swing gate needs two sets of photo eyes for the best area protection (see figure).

One set of photo eyes pointing across the drive on the outside of the hinge post (A). The second set mounted across the drive at the point where the gate is fully opened (B). The photo eye must be installed where the gate does not break the beam.



#550011

Vehicular Protection Shown Below - Entrapment Protection Must Protect Entrapment Areas page 1

The primary unit (Receiver) should be installed close to the control box.  
It requires 4 wires to be installed from the unit to the control box.

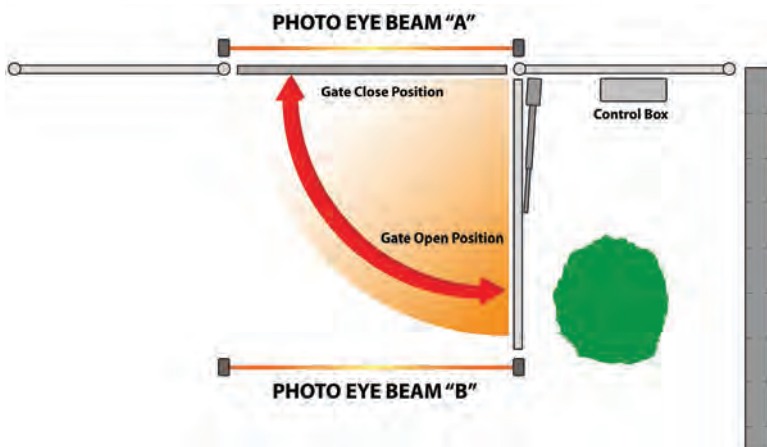

The second unit (Transmitter) can be hard wired or battery powered, if using part # 550011 and should be installed on the opposite side of the drive.

Hard wired Photo Eye (550011) requires 2 wires to be installed from the unit to the control box.

The two units must face each other to establish the beam (maximum distance 40 feet).

When utilizing the PEPM software the photo eye will only be powered up when the gate is operating.

## Installing Photo Eye For Vehicular Protection Only - NOT MONITORED

The photo eye must be wired as shown and the correct dipswitches must be turned on for the PEPM software to work correctly. Detailed instructions are below with illustration.

**NOTE:** Monitored Entrapment UL325 photo eye installation instructions refer to page 20 step 14a.

1. Connect photo eye power wire +12 vdc to J2 pin 12.
2. Connect photo eye power ground to J2 pin 2 or pin 7.
3. Wire the RX relay N/O contact from the photo eye to J2 pin 11. No 10k
4. Wire the RX relay common from the photo eye to J2 pin 2 or pin 7.
5. Turn OFF SW1 switch 3 and 4 (temporarily to provide power for installation)
6. Turn on dipswitch SW1 switch 10 photo eye power enable.
7. Install Photo eye and adjust beam – verify proper operation.
8. Once installed turn ON SW1 appropriate dipswitches for gate 1 or gate 2 or both for dual gates.

Test photo eye for proper operation, when gate is closing and beam is broken gate should stop and reverse to full open. If gate is open and beam is broken gate will not close.

**NOTE:** Power is applied to photo eye just before gate operation begins and turns off when gate stops.

**\*IMPORTANT - Photo Eye connecting to J2 pin 11 MUST NOT have a 10K resistor installed.**

SW1 dip switch 10 -  
Photo Eye Power  
Management Enable

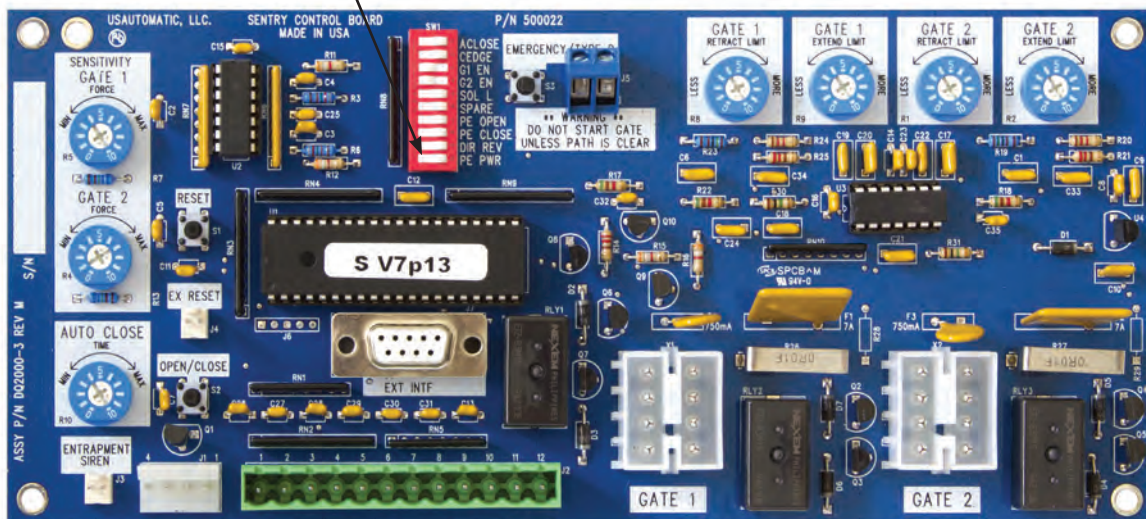

## **B** USAutomatic Battery Controller

Battery controller is designed to charge 12 vdc batteries of various types using either solar panel or DC transformer part # 520009. It also capable of charging 24 vdc battery if using a 24-volt solar panel. The package includes Power source input adapter plug.

**Recommend battery types:** SLA (Sealed Lead Acid), FLD (Flooded Lead Acid), GEL and AGM are all ideal choices. We do not recommend using Lithium-ion batteries with this controller.

Controller Features		
12 / 24 vdc battery detection	Battery voltage reading active	PWM charging mode
Battery reverse connection protection	Battery reverse discharge protection	USB power outlet
LCD display	Temperature compensation	Plug N Go connections
Controller Specifications		
10-amp solar charger	6.2 in x 2.75 in x 1 in	Weight 4.2 oz
DC adapter 20vdc @ 1.2 amps max	Float charging 13.8 / 27.6 vdc	Max solar panel 130 watts
Self-consumption < 9ma	USB max current 1.5 amps	Under voltage cutoff 10.5 vdc

### Installation

The controller is fully automatic for easy and quick installation.

1. Connect battery to the controller.
2. Controller LCD screen will display current battery voltage.
3. Connect Power source input adapter plug to controller power source input
4. Connect Power Source to controller (solar panel or DC transformer)



#### Power Source Inputs:

1. DC power plug 2.5mm
2. Direct wire leads 14-18 gauge

#### Battery Connections:

1. Anderson Power Plug

### Operation

- Charging Indication Symbol when steady indicates that the power source is charging the battery.
- No symbol indicates power source is not supplying enough energy to charge.
- No symbol indicates power source polarity is reversed, verify power source polarity.

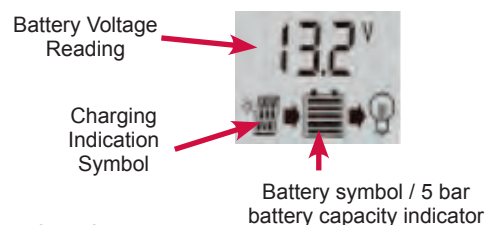

*\*If the symbol is flashing, the battery is fully charged and has entered float charging state.*

### Diagnostics

1. Controller LCD screen is blank:
  - A. Battery voltage below cutoff voltage. Load test battery replace or charge as necessary.
  - B. Reverse battery connection indication. Verify battery polarity connection to controller.
2. Battery symbol is flashing – indicates the battery voltage exceeds the rated input voltage of the charger. Disconnect the external battery charger from battery or choose appropriate battery.
3. Display E11 fail code - battery too low to charge. Remove and have battery load tested

### Warning

**Risk of explosion! Never install the controller in a sealed enclosure with flooded batteries.**



## **C** Installing the APP receiver to the Control Board

The USAutomatic NEXXGATE receiver module connects to the J7 plug on the control board. Follow the instructions included with the NEXXGATE receiver for setup.

For solar charged systems a 20 watt panel is recommended part #520030



# Sentry 300

## WARRANTY AND REPAIR INFORMATION

If your Sentry Automatic Gate Opener is not operating properly, please follow all troubleshooting procedures in the Troubleshooting Guide in this Manual. If you are unable to solve the problem, call USAUTOMATIC at 1-866-711-0001, or visit our web site at [www.sentrygateopener.com](http://www.sentrygateopener.com). We will help with troubleshooting and arrange repair or replacement, if needed. When you call, please have the model and serial number of the Sentry Automatic Gate Opener.

**CONSUMER AFTER INSTALL: Register warranty online at [www.sentrygateopener.com](http://www.sentrygateopener.com). Retain your sales receipt for proof of purchase and date purchased.**

**NOTE: PRODUCT MUST BE REGISTERED WITHIN 30 DAYS OF PURCHASE TO BE COVERED.**

### 3 YEAR WARRANTY

#### Warranty Coverage

If your Sentry Gate Opener, also referred to as the "Product", does not work properly due to a defect in materials or workmanship, USAutomatic will, for the length of 3 years, which begins on the date of the original purchase, at its option either (a) repair your Product with new or refurbished parts, or (b) replace it with a new or refurbished Product. The repair or replacement of the Product will be made free of charge including parts, shop labor, and return to customer shipping and handling.

In all cases, the decision to repair or replace will be made by USAutomatic. Included shop labor does not apply to removal or installation of the Product on purchaser's home or premises. Product must be shipped, at purchaser's expense, to USAutomatic during the applicable Warranty period. The Warranty excludes both parts and labor for batteries, and cosmetic parts such as product housing and paint finishes. The Warranty only applies to Products purchased in the United States and is extended only to the original purchaser of a new product that was not sold "as is".

#### Warranty Service

**For assistance in the continental U.S.A. in obtaining the benefit of the Warranty please carefully follow these steps:**

1. Complete carefully all troubleshooting procedures in the Troubleshooting Guide in this Manual.
2. If you are still unable to solve the problem, contact US Automatic customer service 1-866-711-0001. Please have the model and serial number of the Product available to give to the customer service representative. The customer service representative will provide further assistance or authorize repair or replacement, as appropriate.
3. If repair or replacement is appropriate, you will be given a return authorization number (RMA#). This RMA# must be visible on all documents and packages returned to US Automatic.
4. Carefully pack the defective Product or Product part in a sturdy shipping carton, include (1) a letter detailing the problem, (2) a daytime phone number where you can be reached, (3) your name and address for any return, (4) your sales receipt/proof of purchase, and (5) the RMA# on all correspondence and the shipping carton.
5. Prepay the freight and insure the defective Product or Product parts against shipping damage. Note that defective Products or Products parts shipped freight collect will not be accepted.
6. Ship the carton to US Automatic, LLC, 170 Valley Ridge Blvd., Lewisville, Texas 75057, or where directed by the customer service representative.

**IF REPAIR OR REPLACEMENT IS NEEDED DURING THE WARRANTY PERIOD, THE PURCHASER WILL BE REQUIRED TO FURNISH A SALES RECEIPT/PROOF OF PURCHASE INDICATING DATE OF PURCHASE, AMOUNT PAID AND PLACE OF PURCHASE. THE PURCHASER WILL BE CHARGED FOR THE REPAIR OF ANY PRODUCT OR PRODUCT PART RECEIVED WITHOUT SUCH PROOF OF PURCHASE OR FOR REPAIRS REQUESTED OUTSIDE OF THE APPLICABLE WARRANTY PERIOD.**

**Warranty Limitations and Exclusions**

This Limited Warranty ONLY COVERS failure due to defects in materials or workmanship, and DOES NOT COVER normal wear and tear or cosmetic damage, The Warranty ALSO DOES NOT COVER damages which occurred in shipment , or failures which are caused by products not supplied by USAutomatic, or failures which result from accidents, misuse, abuse, neglect, mishandling, misapplication, or alterations, faulty installation, connection to an improper power source, set-up adjustments, misadjustment of controls, improper maintenance, power line surges, damage from acts of God such as lightning, wind, fire, flood or insects, introduction of sand, humidity or liquids, commercial or rental use or service by anyone other than an Authorized Sentry Repair Center. THERE ARE NO EXPRESS WARRANTIES EXCEPT AS STATED UNDER “WARRANTY COVERAGE”. USAUTOMATIC IS NOT LIABLE FOR INCIDENTAL OR CONSEQUENTIAL DAMAGES RESULTING FROM THE USE OF THE PRODUCT, OR ARISING OUT OF ANY BREACH OF THIS LIMITED WARRANTY. (As examples, this excludes damages for lost time, lost calls or messages, cost of having someone remove or re-install Product or Product part, travel to and from an Authorized Sentry Repair Center, etc. The examples listed are not an exhaustive or exclusive list, but are illustration only). ALL EXPRESS AND IMPLIED WARRANTIES, INCLUDING ANY IMPLIED WARRANTIES OF MERCHANTABILITY OR FITNESS FOR A PARTICULAR PURPOSE, ARE LIMITED TO THE PERIOD OF THE WARRANTY.

Some States do not allow the exclusion or limitation of incidental or consequential damages, so the above limitation or exclusion may not apply to you. Some States do not allow limitations on how long an implied warranty lasts, so the above limitation may not apply to you. This warranty gives you specific legal rights, and you may also have other rights which vary from State to State.

**PARTS AND SERVICES WHICH ARE NOT EXPRESSLY COVERED BY THIS WARRANTY ARE YOUR RESPONSIBILITY.**

**To register your Sentry 300 online:**

[www.sentrygateopener.com/Sentry\\_warranty.php](http://www.sentrygateopener.com/Sentry_warranty.php)

USAutomatic, LLC  
170 Valley Ridge Blvd.  
Lewisville, Tx 75057  
866-711-0001

Keep this information for your records

Model: \_\_\_\_\_ Serial Number\*: \_\_\_\_\_

Date of Purchase: \_\_\_\_ / \_\_\_\_ / \_\_\_\_ Purchased from: \_\_\_\_\_

*\*Serial number can be found by opening cover and looking on the control board.*



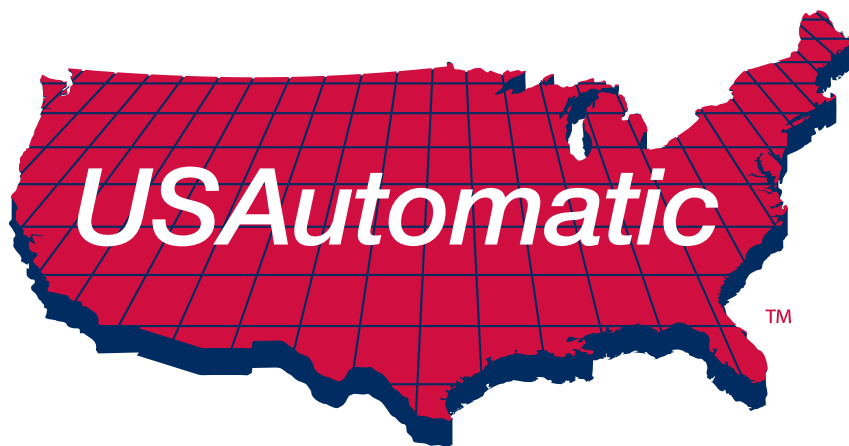

© USAutomatic, LLC, 2021 rev. A

*All rights reserved. No part of this may be reproduced by any means  
without the expressed written consent of the publisher.*



**PROUDLY MADE IN THE USA**  
**[www.sentrygateopener.com](http://www.sentrygateopener.com)**

